

DOC # 0665170
01/09/2006 10:13 AM Deputy: GB

OFFICIAL RECORD

Requested By:

STEWART TITLE OF DOUGLAS

COUNTY

Douglas County - NV

Werner Christen - Recorder

Page: 1 Of 71 Fee: 84.00

BK-0106 PG-01883 RPTT: 0.00



APN _____

Recording Requested By:

Stewart Title of Douglas County

1663 US Highway 395 N, Ste. 101

Minden, NV 89423

AMENDED AND RESTATE DECLARATION OF
(Title of Document)
COVENANTS, CONDITIONS AND RESTRICTIONS
AND RESERVATIONS OF EASEMENTS FOR
ROCKY TERRACE

This document is being re-recorded to correct the signature page

This page added to provide additional information required by NRS 111.312 Sections 1-2.
(Additional recording fee applies)

DOC # 0656738
10/03/2005 02:59 PM Deputy: KLJ

OFFICIAL RECORD

Requested By:

STEWART TITLE OF DOUGLAS

COUNTY

Douglas County - NV

Werner Christen - Recorder

Page: 1 Of 68 Fee: 81.00

BK-1005 PG-00667 RPTT: 0.00

When Recorded mail to:
Rocky Terrace Homeowners Association
C/o Community Association Management Co.
2240 Meridian Blvd. Suite #D
Minden, NV 89423

Amended and Restated

DECLARATION OF COVENANTS, CONDITIONS AND RESTRICTIONS

And

RESERVATIONS OF EASEMENTS

FOR

Rocky Terrace



0665170 Page: 2 Of 71 BK- 0106
PG- 1884
01/09/2006

TABLE OF CONTENTS

RECITALS	1
ARTICLE 1. DEFINITIONS.....	2
1.1 Absolute Majority.....	2
1.2 Act	2
1.3 Additional Charges.....	2
1.4 Architectural Control Committee.....	3
1.5 Architectural Design Guidelines	3
1.6 Articles.....	3
1.7 Assessment.....	3
1.8 Association.....	3
1.9 Board of Directors.....	3
1.10 Bylaws	3
1.11 Common Elements	3
1.12 Common Water Facilities	4
1.13 Contract Purchaser/Contract Seller	4
1.14 County.....	4
1.15 Declarant	4
1.16 Declaration.....	4
1.17 Declaration of Annexation.....	4
1.18 Director.....	4
1.19 Front Yard Area.....	4
1.20 Governing Documents.....	4
1.21 Improvement	5
1.22 Lot.....	5
1.23 Member.....	5
1.24 Member in Good Standing.....	5
1.25 Mortgage.....	5
1.26 Owner	5
1.27 Phase.....	5
1.28 Properties	5
1.29 Record	6
1.30 Residence	6

BK- 0106
 PG- 1885
 01/09/2006
 0665170 Page: 3 Of 71

1.31	Resident	6
1.32	Rules	6
1.33	Simple Majority.....	6
1.34	Subdivision Map.....	6
1.35	Supplemental Declaration.....	6
1.36	Total Voting Power	6
ARTICLE 2. HOMEOWNERS' ASSOCIATION		6
2.1	Management and Operation	6
2.2	Membership	7
2.3	Voting	7
2.4	Executive Board	7
2.5	Mortgage of Association Property	8
2.6	Mergers and Consolidations.....	8
2.7	Dissolution	8
2.8	Limitation of Liability	8
2.9	Payment of Taxes	9
2.10	Insurance	9
ARTICLE 3. COMMON ELEMENTS		9
3.1	Purpose of Common Elements	9
3.2	Conveyance of Common Elements	9
3.3	Owners Non-Exclusive Easements of Enjoyment.....	9
3.4	Assignment of Rights of Use	10
3.5	Common Elements Construction.....	11
3.6	Mechanic's Liens	11
ARTICLE 4. USE RESTRICTIONS		12
4.1	Single Family Residential Use	12
4.2	No Partition.....	12
4.3	Restriction on Businesses	12
4.4	Offensive Conduct, Nuisances, Noise	12
4.5	Agricultural Operations Not a Nuisance.....	12
4.6	Use of the Common Elements.	13
4.7	Requirement of Architectural Approval	13
4.8	Dust Control	13
4.9	Mineral Exploration.....	13



4.10	View Obstruction	13
4.11	Height Limits	13
4.12	Snow Removal	14
4.13	Fire Protection	14
4.14	Sports Apparatus	14
4.15	Window Coverings	14
4.16	Signs	14
4.17	Antennas	15
4.18	Trash Disposal	16
4.19	No Open Burning	16
4.20	Vehicles and Parking	16
4.21	Garages and Driveways	17
4.22	Outbuildings and Temporary Structure	18
4.23	Compliance with Laws	18
4.24	Animals	18
4.25	Rental of Lots	19
4.26	Clotheslines	21
4.27	Mailboxes and Exterior Newspaper Tubes	21
4.28	Activities Affecting Insurance	21
4.29	Storage of Personal Property	21
4.30	Drainage Patterns	21
4.31	No Group Homes	21
4.32	Sight Distance at Intersections	22
4.33	Indemnification	22
4.34	Variances	22
ARTICLE 5. MINIMUM CONSTRUCTION STANDARDS		23
5.1	Approval by Architectural Control Committee	23
5.2	Licensed Contractors	23
5.3	Diversity of Design	23
5.4	Square Footage Minimum	23
5.5	Building Setbacks	23
5.6	No Temporary Structures	24
5.7	Completion of Residence	24
5.8	Exterior Building Materials, Colors and Finishes	24

5.9	Roofs.....	24
5.10	Drainage.....	24
5.11	Exterior Lighting and Fixtures.....	25
5.12	Front Yard Landscaping.....	25
5.13	Fences.....	26
5.14	Slope Stabilization.....	26
5.15	Construction Materials, Construction Debris.....	26
5.16	Water Conservation.....	26
5.17	Soil and Water Conditions.....	26
5.18	Utilities.....	26
ARTICLE 6. ASSESSMENTS AND LIENS.....		27
6.1	Covenant of Owner.....	27
6.2	Creation of Lien.....	27
6.3	Purpose of Assessments.....	27
6.4	Authority of the Board/Ratification by Members.....	27
6.5	Regular Assessment.....	28
6.6	Special Assessments.....	28
6.7	Reimbursement Assessments.....	29
6.8	Enforcement Assessments.....	29
6.9	Failure to Fix Assessments.....	29
6.10	Offsets.....	29
6.11	Delinquent Assessments.....	29
6.12	Late Charges.....	30
6.13	Power of Sale.....	30
6.14	Commencement of Foreclosure Proceedings.....	31
6.15	Certificate of Outstanding Balance.....	31
6.16	Priority.....	31
6.17	Association Funds.....	31
6.18	Allocation of Expenses of Water Service.....	31
6.19	Waiver of Exemptions.....	31
6.20	Property Exempt From Assessments.....	31
6.21	Deferred Assessments Payable by Declarant.....	32
ARTICLE 7. MAINTENANCE OF PROPERTY.....		32
7.1	Association Responsibilities.....	32



7.2 Owner Responsibilities 32

7.3 Compliance with Architectural Provisions 34

7.4 Owner Failure to Maintain 34

7.5 Owner Liability 34

7.6 Authority for Entry of Lot 34

7.7 Association Liability 35

7.8 Board Discretion 35

7.9 Cooperative Maintenance Obligations 35

ARTICLE 8 ARCHITECTURAL CONTROLS 35

8.1 Submission of Plans and Specifications 35

8.2 Establishment of Architectural Control Committee 35

8.3 Duties 35

8.4 Meetings 36

8.5 Architectural Design Guidelines 36

8.6 Application 36

8.7 Fees 36

8.8 Construction Deposit 37

8.9 Grant of Approval 37

8.10 Form of Approval 37

8.11 Time for ACC Action 37

8.12 Board Review 38

8.13 Commencement 38

8.14 Completion 38

8.15 Inspection 38

8.16 Preliminary Approval 39

8.17 Non-Waiver 40

8.18 Estoppel Certificate 40

8.19 Notice of Noncompliance 40

8.20 Liability 41

8.21 Compliance with Governmental Requirements 41

ARTICLE 9. EASEMENTS 41

9.1 Easements in General 41

9.2 Utility Easements 41

9.3 Easements Granted by Board. 42

BK- 0106
PG- 1889
0665170 Page: 7 Of 71 01/09/2006

9.4 General Association Easements for Maintenance42

9.5 Encroachment Easements42

9.6 Utility Maintenance and Repair Easements42

9.7 Declarant’s Easements43

ARTICLE 10. ENFORCEMENT43

10.1 Violations as Nuisance43

10.2 Violation of Law43

10.3 Owners' Responsibility for Conduct and Damages43

10.4 No Avoidance44

10.5 Rights and Remedies of the Association44

10.6 Disciplinary Rules45

10.7 Emergency Situations46

10.8 Non-Waiver46

10.9 Notices46

10.10 Costs and Attorneys' Fees46

10.11 Indemnification46

ARTICLE 11. INSURANCE47

11.1 Types of Insurance Coverage47

11.2 Coverage Not Available48

11.3 Copies of Policies48

11.4 Individual Owner’s Property Insurance48

11.5 Trustee48

11.6 Adjustment of Losses48

ARTICLE 12. DAMAGE OR DESTRUCTION; CONDEMNATION49

12.1 Damage to or Destruction of Improvements to Association Property49

12.2 Damage to or Destruction of Improvements to Lots49

12.3 Condemnation of Common Elements49

12.4 Condemnation of Lots49

ARTICLE 13. PROTECTION OF LENDERS50

13.1 Assessment Lien Subordinated50

13.2 Default by Owner; Mortgagee's Right to Vote50

13.3 Breach; Obligation after Foreclosure50

13.4 Right to Examine Books and Records of the Association50

13.5 Declaration to Conform With Mortgagee Requirements51



ARTICLE 14. ANNEXATIONS AND SUPPLEMENTAL DECLARATIONS 51

14.1 Declarant Annexations..... 51

14.2 Association Annexations 51

14.3 Declarations of Annexation 51

14.4 Assessments in Annexed Phase..... 51

14.5 Supplemental Declarations 51

ARTICLE 15. DECLARANT'S DEVELOPMENT RIGHTS 52

15.1 Declarant's Right to Develop the Properties..... 52

15.2 Use of Common Elements by Declarant..... 52

15.3 Amendment of Development Plans..... 52

15.4 Independent Architectural Review..... 52

15.5 Termination of Declarant's Rights..... 53

15.6 No Amendment or Repeal 53

ARTICLE 16. AMENDMENTS 53

16.1 Amendment before First Close of Escrow..... 53

16.2 Amendment after First Close of Escrow..... 53

16.3 Restatements 54

16.4 Effective Date of Amendment 54

16.5 Amendments by Board 55

16.6 Reliance on Amendment..... 55

ARTICLE 17. GENERAL PROVISIONS 55

17.1 Headings 55

17.2 Severability 55

17.3 Liberal Construction..... 55

17.4 Number; Gender; Shall/May 55

17.5 Easements Reserved and Granted 55

17.6 Power of Attorney 55

17.7 Term..... 56

Exhibit "A" The Development..... 58

Exhibit "B" Fence Design Standards 60



Amended and Restated
DECLARATION OF COVENANTS, CONDITIONS AND RESTRICTIONS
FOR
Rocky Terrace
Homeowners Association

This Declaration of Covenants, Conditions and Restrictions for Rocky Terrace (the "Declaration") is made by Rocky Terrace Estates, LLC, a Nevada limited liability company ("Declarant").

RECITALS

A. Declarant is the owner of certain real property located in Douglas County, Nevada which is more particularly described in Exhibit "A" (the "Development").

B. The Declarant caused to be recorded on December 22, 2004, that certain Declaration of Covenants, Conditions and Restrictions for Rocky Terrace Homeowners' Association, in the office of the County Recorder of Douglas County, Nevada, as document number 0632739, as of said Official Records (collectively, the "Original Declaration"). The recordation of this document shall hereby extinguish in its entirety previous Covenants, Conditions and Restrictions.

C. This Declaration shall apply to all portions of the Development, called Rocky Terrace. Other portions or Phases of the Development may be made subject to this Declaration by annexation in accordance with the terms of Article 15, below. As property is annexed, the annexed property shall become part of the "Properties", as defined herein. The maximum number of Lots contemplated for this Development is ninety (90).

D. Declarant hereby declares that all of the Properties shall be held, sold and conveyed subject to the following easements, restrictions, associations, reservations, covenants, and conditions, all of which are for the purpose of enhancing and protecting the value, desirability and attractiveness of the Properties. These covenants, easements, restrictions, conditions, associations and reservations: (i) create a general plan and scheme for the subdivision development, sale and use of the Properties as a "planned community" as that term is defined in Nevada Revised Statutes Section 116.075; (ii) are for the benefit and protection of the Properties and for the protection and enhancement of the desirability, value and attractiveness of all Lots and Common Elements located therein; (iii) run with the Properties and bind all parties having or acquiring any right, title or interest in the Properties or any part thereof; and (iv) inure to the benefit of the successors and assigns of each Owner of any property within the Properties.



E. It is the further intention of the Declarant to sell and convey residential Lots, subject to the protective covenants, conditions, restrictions, limitations, reservations, liens, grants of easements, rights, rights of way, charges and equitable servitudes between Declarant and such Owners as set forth in this Declaration and any duly adopted amendments thereto.

F. Nothing in this Declaration shall be construed or interpreted to commit Declarant to the development of any portion of the Development in accordance with any present planning, or to the annexation of all or any part of the Development to this Declaration, whether or not it is so developed.

G. All of the real property comprising the Development is held and owned and shall be held, owned, operated, managed, conveyed, hypothecated, encumbered, leased, used, occupied, and improved subject to the following covenants, conditions, and restrictions, all of which are declared and agreed to be in furtherance of a plan and purpose of protecting, preserving, and enhancing the value, desirability, and attractiveness of the Development and every part thereof, and of fostering the Development, management, improvement, enjoyment, and sale of the real property comprising the Development and any part thereof.

H. All of the covenants, conditions, and restrictions set forth in this Declaration shall constitute enforceable equitable servitudes, as well as covenants that shall run with the real property comprising the Development, and shall be binding upon and inure to the benefit of each Owner of any portion of such real property or of any interest therein and their heirs, successors, and assigns.

I. In the 2002 general election the voters in Douglas County approved Douglas County Question 4 which is referred to as the "Slow Growth Initiative" and purports to limit the number of residential permits which can be issued by Douglas County. At the time of this Declaration, Douglas County Question 4 has not been implemented due to litigation and Douglas County may impose restrictions on the issuance of building permits which could affect the Owners of Lots within the Rocky Terrace Development

ARTICLE 1. DEFINITIONS

1.1 Absolute Majority. "Absolute Majority" shall mean Fifty-One Percent (51%) of the Total Voting Power of the Association

1.2 Act. "Act" shall mean the Nevada Common Interest Ownership Act, Nevada Revised Statutes, Chapter 116.001 et seq. as it may be amended from time to time.

1.3 Additional Charges. "Additional Charges" shall mean all costs, fees, charges, and expenditures, including without limitation, interest, late charges, attorneys' fees, Recording and filing fees, and all other costs actually incurred by the Association in collecting and/or enforcing payment of Assessments, fines, and/or penalties.

1.4 Architectural Control Committee. "Architectural Control Committee" or "ACC" shall mean the committee created pursuant to Article 8 of this Declaration.

1.5 Architectural Design Guidelines. "Architectural Design Guidelines" shall mean the development guidelines, rules and regulations adopted by the Architectural Control Committee pursuant to this Declaration.

1.6 Articles. "Articles" shall mean the Articles of Incorporation of the Association, as they may be amended from time to time, and as filed with the Office of the Secretary of State of Nevada.

1.7 Assessment. "Assessment" shall mean a charge levied by the Association against an Owner and his or her Lot as provided in Article 6 of this Declaration. "Assessment" shall include any or all of the following:

(a) Regular Assessment, which shall have the meaning set forth in Section 6.5 of this Declaration.

(b) Enforcement Assessments, which shall have the meaning set forth in Section 6.8 of this Declaration.

(c) Reimbursement Assessments, which shall have the meaning set forth in Section 6.7 of this Declaration.

(d) Special Assessments, which shall have the meaning set forth in Section 6.6 of this Declaration.

1.8 Association. "Association" shall mean the Rocky Terrace Homeowners' Association, a Nevada nonprofit corporation, its successors and assigns.

1.9 Board of Directors. "Board of Directors", "Executive Board" or "Board" shall mean the governing body of the Association. The Board of Directors is an "Executive Board" as defined by Section 116.045 of the Act.

1.10 Bylaws. "Bylaws" shall mean the Bylaws of the Association as they shall be adopted by the Association and any duly-adopted amendments thereof.

1.11 Common Elements. "Common Elements" shall mean all real property owned or maintained by the Association for the common use and enjoyment of the Owners and Residents of the Development including, without limitation, any entry features shown on the Subdivision Map, excluding the Lots and streets and roads which have been accepted for dedication by the governing body having jurisdiction over the same. The Common Elements shall include the masonry perimeter fence and the Common Water Facilities (until transferred and accepted by Douglas County as part of the Gardnerville Ranchos General Improvement District "GRID" water system) as installed by Declarant. While not specifically a Common Element, the off-site detention pond located adjacent to the southwest property line of the Development shall be



maintained by the Association in the same manner as any other Common Element in accordance with an agreement with the County.

1.12 Common Water Facilities. "Common Water Facilities" shall mean the water well and booster pump station, common distribution lines and all other equipment lines, pipes and other apparatus used for the distribution of potable water to the Lots and to other property.

1.13 Contract Purchaser/Contract Seller. "Contract Purchaser" and "Contract Seller" shall mean the purchaser and the seller, respectively, under an installment land contract in which title to the property is transferred after the final installment payment is made.

1.14 County. "County" shall mean Douglas County, Nevada.

1.15 Declarant. "Declarant" means Rocky Terrace Estates, LLC, a Nevada limited liability company. The term "Declarant" shall also mean any successor or assign of Declarant, provided a certificate, signed by Declarant and Declarant's successor or assign, is Recorded against the portion of the Development which the successor or assign assumes the rights and duties of Declarant.

1.16 Declaration. "Declaration" shall mean this instrument, as it may be amended from time to time. If any Supplemental Declarations or Declarations of Annexation are approved and recorded in accordance with this Declaration then following such recordation any reference to this Declaration shall mean this Declaration as amended and supplemented by the Supplemental Declaration(s) and any Declarations of Annexation.

1.17 Declaration of Annexation. "Declaration of Annexation" means a declaration annexing portions of the Development to the Properties and subjecting the real property described therein to this Declaration, all as more particularly described in Article 15, below.

1.18 Director. "Director" shall mean a member of the Board of Directors of the Association.

1.19 Front Yard Area. "Front Yard Area" shall mean that portion of each Lot which is generally visible from any street within the Development and would commonly be referred to as a front yard or side yard. Front Yard Area shall not include those portions of a Lot which are covered by structural Improvements (including sidewalks and driveways) or which are enclosed for the private use of a Resident. The precise area of each Lot which constitutes the Front Yard Area shall be determined by the Board.

1.20 Governing Documents. "Governing Documents" shall mean the Articles, Bylaws, Declaration, Rules (including the Architectural Design Guidelines), and the policies and resolutions duly adopted by the Board and distributed to the Members.

1.21 Improvement. "Improvement" shall mean all structures and improvements including without limitation, Residences, buildings, landscaping, paving, fences, and signs.

1.22 Lot. "Lot" shall mean any plot of land shown upon the Subdivision Map, with the exception of the Common Elements and shall have the same meaning as the term "unit" as used in the Act.

1.23 Member. "Member" shall mean an Owner.

1.24 Member in Good Standing. "Member in Good Standing" shall mean a Member of the Association who is current in the payment of all dues, Assessments, fines, penalties, and other charges imposed in accordance with the Governing Documents, and who is in compliance with all of the provisions of the Governing Documents, as may be more particularly set forth in the Bylaws.

1.25 Mortgage. "Mortgage" shall mean a deed of trust as well as a mortgage in the conventional sense. "First Mortgage" shall mean any Recorded Mortgage on a Lot with first priority over other Mortgages on such Lot. "Mortgagee" shall mean any person, company, bank, institution or other licensed entity which provides a Mortgage to any Owner on any Lot.

1.26 Owner. "Owner" shall mean any person, firm, corporation or other entity in which fee title to a Lot is vested as shown by the official records of the office of the County recorder, including Contract Sellers, but excluding Contract Purchasers and excluding those having such interest merely as security for the performance of an obligation. If a Lot is transferred or conveyed to a trust, the Owner is the trustee or the co-trustees of such trust. A person or entity is not an Owner due to (a) community property or other equitable rights not shown of Record; or (b) rights of adverse possession not shown of Record. Where the context requires, the term "Owner" shall include the members of the Owner's household and the Owner's guests, tenants/lessees and invitees; provided, however, that such persons are not "Owners" for purposes of exercising voting rights in the Association.

1.27 Phase. "Phase" means, if and when a Declaration of Annexation has been recorded, all of the real property annexed by any Declaration of Annexation. If a Declaration of Annexation designates the property annexed as being more than one (1) Phase, each such designated Phase shall be a Phase.

1.28 Properties. "Properties" means all parcels of real property (Common Elements and Lots) described in Exhibit "A", together with all buildings, structures, utilities, Common Facilities, and other Improvements now located or hereafter constructed or installed thereon, and all appurtenances thereto. The term "Properties" shall also include any additional real property that is hereafter annexed to the real property described in Exhibit "A" and made subject to this Declaration pursuant to Article 14, below.

1.29 Record. "Record" Recording", "Recorded", "Recordation" and "Filing" shall mean, with respect to any document, the recordation or filing of such document in the office of the County recorder.

1.30 Residence. "Residence" shall mean a residential structure located upon a Lot which is designed for human residential use and occupancy.

1.31 Resident. "Resident" shall mean any person who resides on a Lot within the Development whether or not such person is an Owner as defined in Section 1.26 of this Declaration.

1.32 Rules. "Rules" shall mean the rules and regulations governing the use, occupancy, management, administration, and operation of the Development or any part thereof as adopted and published by the Board of Directors from time to time, and the Architectural Design Guidelines as adopted and published by the Architectural Control Committee from time to time.

1.33 Simple Majority. "Simple Majority" shall mean a majority of the votes of the Members (i) represented and voting at a meeting at which a quorum is present, or (ii) cast by written ballot in which the number of ballots received equals or exceeds the number required to establish a quorum.

1.34 Subdivision Map. "Subdivision Map" shall mean the subdivision map for Rocky Terrace which has been or will be recorded with the County.

1.35 Supplemental Declaration. "Supplemental Declaration" means any declaration Recorded pursuant to Section 14.5, below, which supplements this Declaration and which may affect solely a Phase of the Development.

1.36 Total Voting Power. "Total Voting Power" shall mean the total number of votes of all Members entitled to vote at a particular time, calculated on the basis of one vote for each Lot, excluding any Lots as to which an Owner is not then a Member in Good Standing.

ARTICLE 2. HOMEOWNERS' ASSOCIATION

2.1 Management and Operation. The Association, through the Board of Directors, shall manage and operate the Development in accordance with the applicable provisions of the Governing Documents and the applicable provisions of Nevada law. The Association shall have all of the powers set forth in the Rocky Terrace Governing Documents together with general power to do any and all things that a not for profit corporation may lawfully do under the laws of the State of Nevada, subject only to the limitations upon the exercise of such powers as are expressly set forth in the Governing Documents.

2.2 Membership. Every Owner of a Lot shall be a Member of the Association

and shall remain a Member thereof until such time as his or her Lot ownership ceases for any reason. Membership shall be appurtenant to and may not be separated from ownership of a Lot and shall not be transferred, encumbered, pledged, alienated, or otherwise hypothecated in any way, except in connection with the sale or encumbrance of the Lot to which it is appurtenant.

2.3 Voting.

(a) **Commencement of Voting Rights.** Voting rights attributable to the ownership of Lots shall not vest until Assessments against those Lots have been levied by the Association.

(b) **Single Classes of Membership.** The Association shall have a single class of voting membership, with each Membership vote being an equal fraction of the total number of Memberships of the Rocky Terrace Homeowners' Association. However, the Declarant shall have the right to appoint and remove the officers and the Executive Board during the period of Declarant's control, as more particularly provided in the Bylaws and Section 116.31032 of the Act.

(c) **Membership Voting Rights.** Only Members in Good Standing shall be entitled to vote.

(d) **Election of Board members:** Election of board members must be done by secret written ballot, pursuant to the provisions of the Act.

(e) **Suspension of Voting Rights.** Voting rights may be temporarily suspended under those circumstances described in Article 10.5(b), below.

(f) **Proxies:** A Proxy may be used in voting in accordance with the provisions of the Bylaws and pursuant to the provisions of the Act; however, a vote may not be cast pursuant to a proxy for the election or removal of a member of the Executive Board. The proxy must immediately terminate after the conclusion of the meeting for which it is executed.

2.4 Executive Board. The affairs of the Association shall be managed by or under the direction of a Board of Directors. The number and qualifications of Directors shall be as established in the Bylaws, and the members of the Board shall be elected and appointed as provided in the Bylaws. The Board of Directors shall have all of the powers and duties set forth in any provision of the Governing Documents, including without limitation the following powers and duties:

(a) **Association Rules.** The Board of Directors shall have the power and the authority to establish, promulgate, amend, repeal, and enforce such rules and regulations, which shall be known as "Rules", as the Board deems necessary for the management and operation of the Development and the conduct of business and affairs of the Association. The Rules may concern, but need not be limited to, matters pertaining to use of the Common Elements, pets, signs, collection and

disposal of refuse, minimum standards for maintenance of property, use of recreation facilities, parking and traffic regulations, rental or leasing of Lots, and any other subject matter within the jurisdiction of the Association as provided in the Governing Documents or by law.

(b) **Manager and Other Personnel.** The Board of Directors shall have the power and authority to employ a manager and such other persons or entities as the Board shall deem appropriate to assist it in managing and maintaining the Development and conducting the business and affairs of the Association, as more particularly set forth in the Bylaws.

(c) **Capital Improvements.** The Board of Directors shall have the power and authority to provide for the construction, reconstruction, installation, or acquisition of capital improvements upon the Common Elements.

(d) **Transfer or Dedication of Common Elements to Public Agency or Utility.** The Board of Directors shall have the power to dedicate or transfer all or any part of the Common Elements to a public agency, authority or utility or other person or entity for such purposes and subject to such conditions as may be agreed to by the Board.

(e) **Borrow Money.** The Board of Directors shall have the power to borrow money in the name of the Association. Any such transfer shall require the consent of a majority of the Total Voting Power of the Association.

2.5 **Mortgage of Association Property.** The Board of Directors shall have the power and authority to mortgage, pledge, encumber, or otherwise hypothecate the real and personal property of the Association for money borrowed or debts incurred by the Association. Any such mortgage or encumbrance shall require the consent of a majority of the Total Voting Power of the Association.

2.6 **Mergers and Consolidations.** Subject to the agreement of the Lot Owners, the Association may (i) participate in mergers and consolidations with other not for profit corporations organized for the same purposes as the Association, or (ii) annex additional property to the Development, in accordance with Section 15.2, below.

2.7 **Dissolution.** So long as there is any Lot, parcel or area for which the Association is obligated to provide management, maintenance, preservation or control, the consent of all Members must be obtained for the Association to (i) transfer all or substantially all of its assets, or (ii) file a certificate of dissolution.

2.8 **Limitation of Liability.** Neither the Association or its directors, officers, employees, agents or committee members (collectively and individually referred to as the "Released Party") shall be personally liable for damages or in equity to any of the Members, or to any other person, for any error or omission in the discharge of their duties and responsibilities or for their failure to provide any service required hereunder or pursuant to the Bylaws, even if such Released Party is negligent, provided that such



Released Party has not acted in willfully or with wanton misfeasance or with gross negligence. This standard of care and limitation of liability shall extend, without limitation, to matters such as (i) the establishment of the Association's annual financial budget, (ii) the funding of Association reserve accounts, (iii) the discharge of the Association's maintenance, repair and replacement obligations, (iv) the enforcement of the Governing Documents, and (v) to any other fiduciary duties or responsibilities imposed by law or the Governing Documents.

2.9 Payment of Taxes. The Association shall pay all real and personal property taxes and other taxes and assessments levied upon or with respect to any property owned by or leased to the Association, to the extent that such taxes and assessments are not levied directly upon the Members. The Association shall have all rights granted by law to contest the legality and the amount of such taxes and assessments.

2.10 Insurance. The Association shall obtain and maintain in effect policies of insurance adequate, in the opinion of the Board, in kind and amount. Without limiting the generality of the preceding sentence, such policies of insurance shall include those described in Article 11 of this Declaration.

ARTICLE 3. COMMON ELEMENTS

3.1 Purpose of Common Elements. Subject to the provisions of the Declaration, the Common Elements shall be held, maintained, and used to meet the common interests of the Owners, the members of the Owners' households, and the Owners' tenants, resident Contract Purchasers, and guests as provided in the Governing Documents.

3.2 Conveyance of Common Elements. Declarant shall convey fee simple title to the Common Elements parcels to the Association, free of all encumbrances and liens, with the exception of current real property taxes (which shall be prorated as of the date of such conveyance) and any easements, conditions and reservations then of record, including those set forth in this Declaration. Such conveyance shall be made prior to, or concurrently with, the transfer or conveyance of ownership by Declarant of Fifty Percent (50%) of the Lots in the Development.

3.3 Owners Non-Exclusive Easements of Enjoyment. Every Owner shall have a non-exclusive easement of use of and enjoyment in, to, and throughout the Common Elements. Each such non-exclusive easement shall be appurtenant to and pass with the title to every Lot, subject to the following rights and restrictions:

(a) The right of the Board of Directors to establish and enforce reasonable Rules governing the use of the Common Elements and the facilities thereon including the Board's right to restrict specific access and uses. Off-road vehicles, motor bikes, bicycles and skateboards are prohibited from the Common Elements.

(b) The right of the Board, as more particularly addressed in the Bylaws, to suspend an Owner's right to use the recreational facilities located on the Common Facilities for (i) any period during which any Assessment against such Owner's Lot remains unpaid, and/or (ii) for violations of the Governing Documents by an Owner or any person for whom an Owner is responsible, provided, however that the Board shall not impair an Owner's right to vehicular and pedestrian ingress and egress to or from his or the Lot, including any area used for approved parking;

(c) The right of the Board, as set forth in Section 3.3 of this Declaration, to grant easements and rights of way in, on, over, or under the Common Elements;

(d) The right of the Board to dedicate or transfer all or any part of the Common Elements to any public agency, authority, or utility; subject to the restrictions contained in Section 2.4(d) above;

(e) The right of the Board to mortgage, pledge, encumber, or otherwise hypothecate the Common Elements and facilities thereon as security for money borrowed by the Association;

(f) The right of the Association or its authorized agents to perform its obligations under this Declaration, including, without limitation, obligations with respect to construction, maintenance, repair, or replacement for the benefit of the Common Elements;

(g) The right of the Association to establish, construct, maintain, repair and replace entrance signs, street signs, maps, directories and other similar improvements upon the Common Elements;

(h) The right of the Association to establish, construct, maintain, repair and replace facilities upon the Common Elements including without limitation storage facilities and workshops, which may be necessary or convenient in the discharge of the Association's duties and the exercise of its rights under the Governing Documents; and

(i) The right of Declarant and its employees, sales agents, prospective purchasers, customers and representatives, to enter upon and to use the Common Elements for development and sales activities in accordance with Article 15, below. Such use shall not unreasonably interfere with the rights of use and enjoyment of the other Owners as provided herein.

3.4 Assignment of Rights of Use. Any Owner may assign his rights of use and enjoyment, including easements, in the Development to the members of his household, tenants, Contract Purchasers, guests and invitees, subject to the terms of the Governing Documents. Upon the leasing or renting of a Lot, or upon occupancy of a Lot by a



Contract Purchaser, the Owner shall be deemed to have assigned all such rights exclusively to the tenants or Contract Purchasers of such Lot except that such Owner shall continue to have an easement for ingress and egress to such Owner's Lot to the extent necessary to discharge of the Owner's obligations and rights as a landlord. Each Owner shall notify the Secretary of the Association of the names of any tenants or any such Contract Purchasers of such Owner's Lot. Each Owner, tenant, or Contract Purchaser shall also notify the Secretary of the Association of the names of all members of his or her household to whom such Owner, tenant, or Contract Purchaser has assigned any rights of enjoyment in the Development as provided herein and the relationship which each such person bears to such Owner, tenant, or Contract Purchaser. Any rights of enjoyment assigned pursuant to this section are subject to suspension to the same extent that rights of Owners are subject to suspension as provided in the Governing Documents. It is the express purpose and intent of the provisions of this section to limit the right of use and enjoyment of the Common Elements to Residents and their guests.

3.5 Common Elements Construction. No person or entity other than the Association or its duly-authorized agents (i) shall construct, reconstruct, refinish, alter, or maintain any Improvement upon the Common Elements, (ii) shall make or create any excavation or fill upon the Common Elements, (iii) shall change the natural or existing drainage of the Common Elements, or (iv) shall plant, remove, or destroy any seed, plant material, tree, shrub, or other vegetation upon the Common Elements.

3.6 Mechanic's Liens. In the event there shall be Recorded against the Common Elements a notice of mechanic's lien for, or purporting to be for, labor or materials alleged to have been furnished or delivered for any Owner or his or her Lot, such Owner shall immediately cause such lien to be discharged by payment, bond, or otherwise. If the Owner fails to cause the lien to be discharged, the Board may send written notice to the Owner specifying that unless the Owner causes the lien to be discharged within five (5) days from the date of such notice, the Board may cause the lien to be discharged. Within such five (5) day period, the Owner shall be granted a hearing before the Board regarding the validity of such lien and any offsets or defenses thereto. At that time, the Board shall determine whether the lien adversely and improperly affects and encumbers the rights and interests of the Association or the other Owners. If the Board of Directors determines that the lien does adversely and improperly affect and encumber such rights and interests and that adequate protection of such rights and interests has not been provided, the Board may cause the lien to be discharged by payment, bond, or otherwise. The Board shall have the right to levy a Reimbursement Assessment against the Owner responsible for causing the lien to be discharged in an amount equal to all amounts paid by the Association together with interest thereon at the legal rate and all costs and expenses paid or incurred in connection therewith, including reasonable attorneys' fees.

ARTICLE 4. USE RESTRICTIONS

4.1 Single Family Residential Use. Except as specifically provided in Section



0656738 Page: 19 Of 68 10/03/2005

BK- 1005
PG- 685

BK- 0106
PG- 1902

0665170 Page: 20 Of 71 01/09/2006

4.3, no Lot, or any portion thereof, shall be occupied or used for other than single-family residential purposes. Only one Residence per Lot is permitted and such Residence, and no other building or structure of any kind, may be used as a living area.

4.2 No Partition. There shall be no judicial partition of the Development or any part thereof, nor shall any Owner or any person acquiring any interest in the Development or any part thereof seek any judicial partition thereof. Notwithstanding the preceding, if any Lot is owned by two or more co-tenants as tenants in common or as joint tenants, this section shall not be deemed to prevent a judicial partition by sale as between such co-tenants.

4.3 Restriction on Businesses. No business of any kind, including daycares and schools, shall be established, maintained, operated, permitted, or conducted within the Development except:

(a) Those professional and administrative occupations as may be permitted by, and which are conducted in conformance with, all applicable governmental ordinances provided that there is no external evidence thereof, and further provided that the Board may, in its complete discretion, prohibit the conduct of any such activities which the Board determines to be incompatible with the nature and character of the Development or which, in the Board's opinion, may or does otherwise negatively impact the quality of life and property values within the Development.

(b) Those other businesses which by law must be permitted to be conducted within the Development.

4.4 Offensive Conduct, Nuisances, Noise. No noxious, harmful or offensive activities shall be conducted upon or within any part of the Development, nor shall anything be done thereon which may be or become a nuisance, or cause unreasonable embarrassment, disturbance, or annoyance to any Residents of the Development, or which shall in any way interfere with their use of the Common Elements and facilities thereon or the use and enjoyment of their Lots or Residences. Without limiting any of the foregoing, no Resident shall permit noise, including without limitation the barking of dogs or excessively loud music, to emanate from the Resident's Lot, which would unreasonably disturb another Resident's enjoyment of his or her Lot or of the Common Elements. Nothing in this section shall be construed to limit the Association's ability to discharge its duties in accordance with the Governing Documents or otherwise manage the Development.

4.5 Agricultural Operations Not a Nuisance. The County has declared it a policy to protect and encourage agricultural operations. The Development is located near an agricultural operation and Owners may, at some time, be subject to inconvenience or discomfort arising from agricultural operations. If conducted in a manner consistent with proper and accepted standards, these inconveniences and discomforts do not constitute a nuisance for purposes of the Douglas County Code.

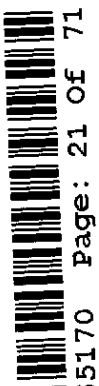

4.6 Use of the Common Elements. All use of the Common Elements is subject to the Governing Documents. No alterations or additions to the Common Elements shall be made except as authorized by the Board pursuant to Section 2.4. With the limited exception of the placement of trash receptacles and containers within the twenty-four hour preceding scheduled trash collection times, nothing shall be placed, kept, stored, or parked on the Common Elements without the prior written consent of the Board, except by the Association. Without limiting the foregoing, no Owner shall place rubbish, debris, or other unsightly or unsanitary materials on the Common Elements. Each Owner shall avoid causing damage to the Common Elements.

4.7 Requirement of Architectural Approval. As addressed in greater detail in Article 8, construction, installation, modification, or alteration of buildings, outdoor structures, fences, outdoor lighting and all other exterior Improvements are subject to approval of the Architectural Control Committee.

4.8 Dust Control. Each Owner shall be responsible for dust control on his or her Lot and such Owner shall be liable for any damage to other properties caused by airborne dust emanating from such Owner's Lot. All Owners and the Association shall conform to all applicable rules and regulations of the Douglas County Air Pollution Control Regulations.

4.9 Mineral Exploration. No portion of the Property shall be used in any manner to explore for or to remove any oil or other hydrocarbons, minerals of any kind, gravel, or earth substance. No drilling, exploration, refining, quarrying, or mining operations of any kind shall be conducted or permitted to be conducted thereon; nor shall wells, tanks, tunnels, mineral excavations, shafts, derricks, or pumps used to mine or drill for any substances be located on the Property. There shall be no deed, conveyance, agreement or other document executed, the terms of which separate surface or subsurface rights into different ownerships.

4.10 View Obstruction. Declarant makes no representations or warranty with respect to the presence or absence of any view from any portion of any Lot. Any existing view may change or be blocked or impaired depending upon construction, landscaping or other activities undertaken on remaining land located within the Property or on land located outside the Property. Each Owner, by accepting title to a Lot in the Property, hereby acknowledges that (a) there are no protected views within the Property, and no Lot in the Property is assured the existence or unobstructed continuation of any particular view, and (b) any construction, landscaping or other installation of improvements by Declarant, or other Owners, may impair the view from any Lot in the Property, and the Owners hereby consent to such view impairment.

4.11 Height Limits. Unless otherwise set forth in any Declaration of Annexation with respect to any Annexed Property and unless otherwise provided by applicable law, no structure shall be more than 35 feet in height as set forth in the Douglas County Code.

4.12 Snow Removal. Snow Removal within the private roads and roads which

have not been accepted by Douglas County for dedication within the Property shall be the responsibility of the Association.

4.13 Fire Protection. Each Owner shall be responsible for fire fuels around such Owner's home site and within such Owner's Lot. A fuels management/reduction program around all structures shall maintain a minimum of 30 feet of distance in accordance with the Uniform Fire Code Appendix II - A - 16 and shall be the responsibility of the individual Owner. Clearance of vegetative growth from roadways, in accordance with Uniform Fire Code Appendix II - A - 17 shall be the responsibility of the Association. All Structures shall be constructed with fire retardant roofing material in compliance with NRS 472.100.

4.14 Sports Apparatus. No sports apparatus, whether portable or fixed, including without limitation basketball standards, which is visible from (i) any Lot other than the Lot upon which it is installed or utilized, (ii) any street within the Development, or (iii) the Common Elements, shall be permitted within the Development except in strict accordance with the following provisions:

(a) Portable Sports Apparatus. The Board of Directors shall have the power, but not the obligation, to permit the use of portable sports apparatus, including without limitation portable basketball standards and skateboard ramps, on any Lot. Use of such portable sports apparatus shall be subject to all rules and regulations, which shall be Rules as defined in Section 1.32, as the Board may in its discretion adopt. Such Rules may include, without limitation, requirements that the apparatus be stored completely out of sight from outside of the Lot when not in use, limitations on the times of day during which such apparatus may be used, and regulations regarding the conduct and noise generated in the use of such apparatus.

(b) Fixed Sports Apparatus. The Board of Directors shall have the power, but not the obligation, to permit the installation of fixed sports apparatus, including without limitation basketball standards, which would otherwise be prohibited by this section upon any Lot provided that: (i) Architectural approval pursuant to Article 8 is obtained, (ii) no fixed sports apparatus shall be installed in any Front Yard Area, and (iii) the installation is in conformance with the provisions of the Declaration.

4.15 Window Coverings. Window coverings shall be of a color that blends with the exterior color of the residence. In no event shall windows be painted, nor shall aluminum foil, newspaper, bed sheets, cardboard or similar materials be placed in windows. All window coverings shall be maintained in good repair and condition at all times.

4.16 Signs. All signage within the Development shall be strictly controlled by the Association and any sign not in compliance with these restrictions is subject to immediate removal by the Association with the Owner of the Lot upon which the sign was removed being fully responsible for any costs of removal. No sign of any kind shall



be displayed to the public view from any portion of the Development except that this restriction shall not apply to:

- (a) Signs required by legal proceedings;
- (b) Signs which by law cannot be prohibited;
- (c) A single sign of customary and reasonable dimension and design, complying with the Rules and reasonably located on a Lot advertising the Lot for sale or rent;
- (d) A single identification sign which has been approved by the Board of Directors located on a Lot identifying the number or address of the Lot and/or the name of the Owner of the Lot;
- (e) Signs approved by the Board located at or near any entrance to the Development identifying the Development;
- (f) Signs required for traffic control and regulation of streets or open areas within the Development; and
- (g) Such other signs as the Board, in its discretion, may approve. The Board may adopt limitations on such signs including, without limitation, restrictions on the size of the signs, the duration of their posting, and their location.

4.17 Antennas. No outside mast, tower, pole, antenna, or satellite dish shall be erected, constructed, or maintained on the Common Elements or upon any Lot, except as provided in this Section. Provided that the application of these restrictions does not unreasonably delay installation, create undo expense, or preclude reception of an acceptable quality signal, Antennas or satellite dishes with a diameter or diagonal measurement not greater than one meter which are designed to receive direct broadcast satellite services, video programming services via multipoint distribution services, or television broadcast signals (collectively "Permitted Dishes") may be erected, placed or installed on a Lot, subject to the following restrictions:

- (a) Installed in locations so as to minimize visibility within the Development.
- (b) Painted to blend into the background against which they are mounted.
- (c) Installed in accordance with a prioritized list of placement preferences, if such a list is adopted by the Architectural Committee.
- (d) Installed in accordance with such reasonable restrictions which may be imposed as part of the Architectural Rules

4.18 Trash Disposal. Trash, garbage, accumulated waste plant material and all other waste and refuse shall be deposited only in covered sanitary containers or recycling containers in accordance with the following provisions:

(a) Except as provided in this Section, the containers shall be maintained upon each Lot and shall be screened or otherwise concealed from view from the Common Elements, the streets or any other Lot.

(b) The containers may be placed for pickup at a reasonable time prior to trash collection and shall be promptly stored as specified in this Section after collection. The Board may adopt Rules regulating the placement of containers for trash collection which Rules may include limitations on the period of time during which containers may be placed for collection.

(c) No Owner or Resident shall permit or cause any garbage, trash or other waste or refuse to be kept upon any portion of any Lot outside of the Residence or elsewhere in the Development, except in such containers.

4.19 No Open Burning. No open burning of removed vegetation, or construction or demolition debris shall occur on any Lot or on the Common Area.

4.20 Vehicles and Parking.

(a) Limitations on Types of Vehicles.

(i) No trailer, motor home, recreational vehicle, camper, or boat, shall be parked, kept, stored, or permitted to remain upon any area within the Development unless placed or maintained completely within an enclosed garage or placed within the side setback of a Lot in which case no portion of the vehicle shall exceed the height of the standard fence nor be visible in any way from the Common Elements and Public-access streets. No additional screening may be added to the height of the standard fence to accommodate a vehicle which is taller than the fence. An exception to this provision shall be that a guest of a Resident may park a recreational vehicle on the driveway on of the visited Lot, for a period not exceeding seventy-two (72) continuous hours. Movement of any such recreational vehicle for the purposes of preventing the application of this section shall be ineffective.

(ii) No dilapidated, unclean, unsightly, inoperable, or abandoned vehicle shall be parked, kept, stored, or permitted to remain upon any area within the Development unless placed or maintained completely within an enclosed garage.

(b) Limitation on Numbers and Parking of Resident and Owner Vehicles.

(i) The Residents and Owners of a single Lot shall not bring into the Development at any one time more vehicles than the number of full-sized vehicles which can be parked completely within the garage serving such Residence, plus two additional vehicles.



(ii) Except as specifically provided in this Section, vehicles of Residents may only be parked wholly within the garage located on the Lot occupied by such Residents or owned by such Owner.

(iii) No more than two vehicles of a Resident or Owner of a Lot may be parked in the driveway located on such Lot and then only if such vehicles do not protrude into the street. Notwithstanding the preceding, no van (other than a van reasonably necessary to meet the transportation needs of a disabled person residing on a Lot), truck or commercial vehicle may be parked within a driveway. The terms "van", "truck" and "commercial vehicle" shall not include sedans, SUV's or standard size pickup trucks and vans (with a payload capacity of one ton or less) which are used for both business and personal uses, provided that any signs or markings of a commercial nature on such vehicles shall be unobtrusive and inoffensive as determined by the Board.

(iv) Notwithstanding the restrictions of this Section, vehicles of guests of any Lot Owner are permitted within the Development for a period not to exceed seventy-two (72) continuous hours.

(c) **Noisy and Polluting Vehicles.** No unreasonably noisy vehicles, off-road only vehicles, unregistered vehicles, and vehicles which do pass state automobile pollution requirements, or emitting foul smelling or offensive exhaust fumes shall be operated within the Development.

(d) **Parking Rules and Enforcement.** In order to prevent or eliminate any parking problems within the Development, or to further define and enforce the restrictions contained in this section, the Board shall have the authority to adopt further reasonable rules and restrictions regarding vehicles and parking within the Development as the Board may deem prudent and appropriate. The Board shall also have the power to impose fines and other sanctions for violations of provisions of the Governing Documents relating to vehicles and parking. Such authority and power shall include, without limitation, the power and authority to fix and impose fines for violations of this section in accordance with the Bylaws.

(e) **Variances.** The Board, in its complete discretion and upon such basis and terms as it deems prudent, shall have the power to adopt, modify and repeal Rules permitting the temporary use and parking within the Development of vehicles otherwise prohibited by the provisions of this section.

4.21 Garages and Driveways.

(a) The residential improvements on each Lot shall include a closed garage or garages that are constructed to accommodate at least three standard-sized motorized passenger vehicles. Carports are not allowed. All garage doors shall be equipped with automatic garage door openers and maintained in good operable condition.

(b) Recreational vehicle or over-sized garages may be allowed if, in the sole discretion of the Architectural Control Committee, the design for such garage has been fully integrated within the overall architectural design of the residence and the roofline of the garage does not exceed the height of the roofline for the remainder of the residence.

(c) Each Owner and Resident shall keep his or her garage and driveway in a neat, orderly, sanitary, and safe condition.

(d) Each garage door shall remain closed except during the time required for the entry and exit of vehicles and individuals and when and only for as long as reasonably necessary in the ordinary and usual uses including hobbies, cleaning, maintenance and other acceptable uses of a garage. Each garage door shall be maintained in good condition, appearance and repair.

(e) Garages may be remodeled or used as a workshop, storage space, hobby facility or for any other use or facility, provided such modification or use still permits the garage to accommodate at least two full-sized passenger vehicles. Any modification to a garage which is visible from outside the Residence is subject to County Ordinances, permits and architectural review as provided in Article 8.

(f) Garage doors shall be constructed to be recessed at least eighteen inches (18") from the exterior wall side.

(g) Driveways shall be constructed of concrete or concrete pavers. Asphalt driveways are not allowed.

4.22 Outbuildings and Temporary Structures. No outbuilding, tent, shack, trailer, shed, cabana, temporary building, umbrella or similar building or structure, shall be located within the Development, except in strict compliance with the provisions of this Declaration, including Article 9. In no event shall any such building or structure be used as a living area.

4.23 Compliance with Laws. Nothing shall be done or kept anywhere within the Development which violates any local, state or Federal law, ordinance, statute, rule or regulation.

4.24 Animals.

(a) Household Pets. No animals, reptiles, rodents, birds, fish, livestock, or poultry shall be raised, bred or kept on any Lot or portion of the Development except that a reasonable number of domesticated birds, cats, dogs or aquatic animals kept within an aquarium, may be kept, provided that they are not kept, bred, or maintained for any commercial purposes and they are maintained under reasonable control at all times, all in conformance with any County ordinances.

(b) **Owner's Responsibility for Pets.** The owner of each pet shall be responsible for immediately removing and disposing of any waste introduced to any portion of the Development by such pet. The Board shall have the power to impose fines and other sanctions for violations of provisions of the Governing Documents relating to pets, including without limitation fines for failure to remove and dispose of pet waste as required by this section. Each Owner, Resident, and any person bringing or keeping an animal within the Development shall be absolutely liable to the Association and all other persons for any injury or damage to persons or property caused by the animal brought upon or kept upon the Development by such person or by members of his or her household, tenants, guests, or invitees. Each Owner and Resident shall indemnify the Association and its officers, directors, and agents against any and all claims, damages, losses, demands, liabilities, and expenses, including but not limited to attorneys' fees, arising out of or resulting from the presence or conduct of any animal brought upon or kept within the Development by the Owner or Resident, members of his or her household, guests, tenants, or invitees.

(c) **Pet Rules.** The Board may adopt and enforce pet rules, which shall be Rules of the Association, in addition to the provisions of this Section. Such Rules may include, without limitation, regulations regarding the presence of pets on the Common Elements and requirements that pets be registered with the Association. The Association shall have the right to prohibit the keeping of any animal which constitutes, in the sole and exclusive opinion of the Board, a nuisance or danger to any other person.

(d) **Pet Rules Pursuant to Hellwinkel Property.** Pet Owners are responsible for pets that may enter, disturb or roam into the property on Centerville Lane known as the Hellwinkel Estate. Pets shall not become a nuisance to this property owner.

4.25 **Rental of Lots.** An Owner shall have the right to rent his or her Lot subject to the provisions of the Governing Documents, including without limitation the following specific requirements:

(a) **Notification of the Board.** The Owner shall notify the Association of the duration of the lease and shall provide the Association with (i) the names of the tenants, (ii) the names of the members of the tenants' household, (iii) the tenants' telephone numbers, and (iv) such other information as the Board deems appropriate. The Association may, in its discretion, adopt a form for the provision of the information required by this subsection, together with an acknowledgment by the tenants that they have read, understand and agree to abide by the Governing Documents, which form shall be submitted to the Association for each rental of a Lot.

(b) **Owner Responsibility.** Each Owner renting a Lot shall be strictly responsible and liable to the Association for the actions of such Owner's tenant in or about all Lots and Common Elements and for each tenant's compliance with



the provisions of all Governing Documents. An Owner renting a Lot shall provide the tenant with copies of the Governing Documents and all subsequent amendments.

(c) **Association's Enforcement Rights.** In the event a tenant's conduct involves damage or misuse of any Common Elements or facilities on any Common Elements or constitutes an unreasonable nuisance to Residents, the Association shall be entitled to maintain an eviction action against such tenant to the same extent as the Owner of the Lot, the Association being deemed to be a third party beneficiary of any lease or rental agreement involving any Lot within the Development. The Association's right to maintain an eviction action shall arise only in the event that (i) the Association has given notice to the Owner detailing the nature of the infraction and the Owner has had a reasonable opportunity to take corrective action or to appear before the Board to present arguments as to why eviction by the Association is not necessary, and (ii) the Owner has not taken action to prevent and/or correct the actions of the tenant giving rise to the damage or nuisance.

(d) **Indemnification of Association.** Every Owner of a Lot that is occupied by persons other than the Owner pursuant to a rental agreement or otherwise, agrees to and shall indemnify and defend the Association, its officers, directors, managers, and agents and shall hold them harmless from any cost, loss, claim, or damages of any kind, including but not limited to attorneys' fees arising out of the conduct or presence of the occupants of the Lot upon the Development, including any such arising or alleged to have arisen out of the enforcement or non enforcement by the Association of the Governing Documents against such occupants. Without limiting the generality of the foregoing, all costs, including attorneys' fees incurred by the Association to enforce the Governing Documents against such occupants, including eviction as provided herein, shall be reimbursed to the Association by the Owner and may be assessed by the Association as a Reimbursement Assessment.

(e) **Requirements of Written Rental Agreement.** Any rental of any Lot shall be only by written rental agreement which shall expressly provide (i) that it is subject to all of the provisions of the Governing Documents, (ii) that the tenants of such Lot shall comply with all provisions of the Governing Documents, and (iii) that any violation of any provisions of the Governing Documents shall constitute a breach and default of the terms of such rental agreement. Pursuant to Section 3.1 of the Bylaws, the rental agreement shall not attempt to, nor shall any such agreement be effective to, transfer membership in the Association to the lessee.

(f) **Requirement of Inclusive Rental Agreement.** No Owner may rent or hire any garage, accessory building, or similar improvement to anyone who does not have the right of possession of the entirety of the Residence on the Lot.

(g) **No Hotel-Like Services.** No rental of a Lot shall be permitted which contemplates or results in the provision of those services typically provided by a

hotel or motel.

(h) **Time-Share Arrangements.** No Lot or Lots or any portion thereof in the Development shall be leased, subleased, occupied, rented, let, sublet, or used for or in connection with any time sharing agreement, plan, program or arrangement, including, without limitation, any so called "vacation license," "travel club," "extended vacation," or other membership or time interval ownership arrangement. The term "time sharing" as used herein shall be deemed to include, without limitation, any agreement, plan, program, or arrangement under which the right to use, occupy, or possess any Lot or Lots or any portion thereof or Residence thereon in the Development rotates among various persons, either corporate, partnership, individual, or otherwise, on a periodically recurring basis for value exchanged, whether monetary or like kind use privileges, according to a fixed or floating interval or period of time. This section shall not be construed to limit the personal use of any Lot or any portion thereof in the Development by any Owner or his or her or its social guests.

(i) **Transient Commercial Uses.** No Lot or Lots or any portion thereof in the Development shall be leased, subleased, occupied, rented, let, sublet, or used under a term of occupancy that is less than thirty (30) consecutive days.

4.26 **Clotheslines.** No exterior clotheslines or other outside clothes drying or airing facility shall be erected or maintained upon any Lot where the same would be visible from the Common Elements, the streets or any other Lot.

4.27 **Mailboxes and Exterior Newspaper Tubes.** Except for the cluster-style, grouped mailboxes which are the mail receptacles for the Lots, no newspapers tubes or mailboxes shall be erected or maintained within the Development.

4.28 **Activities Affecting Insurance.** Nothing shall be done or kept within the Development which will increase the rate of insurance maintained by the Association without the prior written consent of the Association. No Owner shall permit anything to be done or kept within the Development which would result in cancellation of any insurance policy maintained by the Association or any other Owner.

4.29 **Storage of Personal Property.** Items of personal property stored in the front, back, or side yards of Lots shall be kept screened and concealed from view from the Common Elements and public-access streets within the Development.

4.30 **Drainage Patterns.** Except as approved by the Architectural Control Committee or performed by the Association, there shall be no interference with the natural or established drainage systems or patterns within the Development.

4.31 **No Group Homes.** No residence in the Subdivision may be used for a public boarding house, home for a group of unrelated persons operated or financed by a public or private institution, sanitarium, hospital, asylum or institution of any kindred nature, or any use not permitted by local law.



4.32 Sight Distance at Intersections. No fence, wall, hedge or shrub planting which obstructs sight lines at elevations higher than two feet above the roadway shall be placed or permitted to remain on any corner Lot within the triangular area formed by street property lines and a line connecting them at points twenty-five feet from the intersection of the street lines or, in the case of a rounded property corner, from the intersection of the street property lines extended. The same sight-line limitations shall apply on any Lot within ten feet from the intersection of a street property line with the edge of a driveway. No tree shall be permitted to remain within such distances of such intersections unless the foliage line is maintained at sufficient height to prevent obstruction of such sight lines. No fence or hedge exceeding three feet in height shall be erected or permitted to remain or allowed to grow nearer any street than setback lines shown on the Subdivision Map.

4.33 Indemnification. Each Owner, by acceptance of a deed to a Lot, agrees for himself or herself and for the members of his or her household, and his or her Contract Purchasers, tenants, guests or invitees, to indemnify each and every other Owner, and to hold them harmless from, and to defend them against, any claim of any person for personal injury or property damage occurring within the Lot of that particular Owner, except that such Owner's liability may be diminished to the extent that the injury or damage occurred by reason of the negligence of any other Owner or person temporarily visiting such Lot or is fully covered by insurance.

4.34 Variances. The Board shall be authorized to grant reasonable variances from the provisions of Article 4 of this Declaration upon written application from any Owner provided that the Board determines, in its sole discretion, that the specific application of the restriction to such Owner will (i) cause substantial undue hardship to the Owner, or (ii) fail to further or accomplish the common plan for the Development as contemplated by this Declaration. The Board shall have the power to limit any variance granted in scope or duration or otherwise impose such specific requirements as the Board may, in its complete discretion, see fit to require. The Board shall follow the following procedures in acting on any request for a variance:

(a) The Board, in its sole discretion, shall make an initial determination whether or not the variance on its face meets the requirements set forth in this section. If the Board determines that it does not, the variance request shall be denied and the Board shall so notify the applicant within thirty (30) days of the Board's decision. If the Board determines that the variance does, the procedures set forth in the remainder of this section shall be followed.

(b) The Board shall conduct a hearing on the variance within forty-five (45) days of the receipt of the written request for a variance. Notice shall be given to all Members not less than fifteen (15) days prior to the date of the hearing. Members may submit comments in writing prior to the hearing and/or appear at the hearing. The Board shall establish a reasonable time limit for Member comments during the hearing. No decision regarding the request for variance shall be made until the conclusion of the hearing.



(c) After the conclusion of the hearing, the Board shall, in its sole discretion, either grant or deny the request for variance in accordance with the standards set forth in this section. As more fully discussed above, if the Board grants the variance request, the Board may impose such conditions as the Board deems appropriate and shall so notify the applicant, in writing, within thirty (30) days of the Board's decision.

ARTICLE 5. MINIMUM CONSTRUCTION STANDARDS

Unless a variance is requested from, and granted by, the Architectural Control Committee in accordance with Article 8, Improvements constructed on any Lot shall conform to the following minimum construction standards:

5.1 Approval by Architectural Control Committee. No building, landscaping, fence, wall or other permanent structure or Improvement shall be erected, altered or placed on any Lot until building plans, specifications and a plot plan showing the location of structures on the Lots have been submitted to the Architectural Control Committee for review and approval as described in Article 8, below.

5.2 Licensed Contractors. Residential structures shall all be constructed by a contractor licensed under the laws of the State of Nevada. The Architectural Control committee and the Association shall not approve any construction plans or designs unless the Owner first demonstrates that the Owner's building contractor possesses the required state licenses.

5.3 Diversity of Design. Like-design homes are not favored in the Rocky Terrace Development. If the Architectural Control Committee, in its sole discretion, determines that the exterior elevation of a proposed residence is substantially similar to another existing residence within the Development then the construction application shall be denied unless the proposed residence is separated by a minimum of eight (8) Lots along the same street, or is located on a different street, from the site of the existing similar residence. Any residence constructed on a corner Lot shall be designed so that the front door opens to the address street side and the garage opens to the other street.

5.4 Square Footage Minimum. No principal residential dwelling shall be constructed or maintained upon any parcel or lot which shall have total floor areas of less than 2,300 square feet, exclusive of porches, patios, attached and detached garages, outbuildings, breezeways or walks.

5.5 Building Setbacks. Unless more restrictive setback regulations are established by the County, all buildings within the Development shall be designed and constructed so as to conform to the following minimum setbacks as they are described in the design guidelines:

(a) Setback from front (street-side address) property line shall be at least

- twenty-five feet (25').
- (b) Setback from the opposing rear property line shall be at least twenty feet (20').
 - (c) Setback from side property lines (of an adjacent Lot) shall be at least ten feet (10').
 - (d) Setback from a side property line (of a street or Common Element) shall be at least fifteen feet (15').

5.6 No Temporary Structures. No recreational vehicle, trailer, mobile home, camper, tent, shack, used structures, structures of a temporary character, or other outbuildings shall be used on any Lot at any time as a Residence.

5.7 Completion of Residence. Construction of the residence on a Lot must be completed within one (1) year after a grading permit, or if there is no grading permit, a building permit is obtained for the Lot. The Board may adopt Rules and Regulations providing for a schedule of construction penalties for violations of the provisions of this section, which schedule shall be delivered to the Owners in accordance with the applicable law.

5.8 Exterior Building Materials, Colors and Finishes. No exterior materials finishes, colors or textures shall be used without approval of the Architectural Control Committee. Generally, colors shall be restricted to those found in the immediate vicinity of the Residence and colors found in nature will be favored. The Architectural Control Committee shall be authorized, as part of the Design Guidelines, to adopt a chart of approved colors and stains for exterior finishes. All exterior colors, textures and materials, including roof materials, must be adequately described in the plans and specifications (with an indication where the colors will be used upon the finish dwelling) and approved in writing by the Architectural Control Committee prior to initiation of construction. Color samples shall be submitted to the Architectural Control Committee along with the plans and specifications.

5.9 Roofs. The roofing material placed upon any improvement within the Development must be fire retardant, architectural grade composition or tile material which meets the standards set by the Nevada State Forester Fire Warden pursuant to NRS 472.040. Rooftop heating, cooling and air conditioning equipment are not allowed, with the exception of approved solar energy panels which must be installed in such a manner so as to reduce visibility from any Common Element or street.

5.10 Drainage. No Owner shall do any work, construct any Improvement, place any landscaping or suffer the existence of any condition whatsoever which shall alter or interfere with the drainage pattern for the Owner's or any adjacent Lots or parcels or Common Elements as established in connection with the approval of the final subdivision and parcel maps applicable to the Development, except to the extent such alteration in drainage pattern is approved in writing by the Architectural Control Committee, the County, and all other public authorities having jurisdiction. Plans and specifications submitted by an Owner to the Architectural Control Committee in connection with the construction of a Residence or other major structural Improvement shall include a

drainage plan in sufficient detail to permit the Committee to assess the impacts, if any, of the Improvement on natural drainage courses. Finished exterior grades for Lot Improvements shall be sloped away from foundations to provide removal of surface water runoff away from structures. All building pads shall be provided with drainage away from foundations and to a properly controlled discharge system. No surface runoff should be allowed to flow from the pad over an unprotected slope.

5.11 Exterior Lighting and Fixtures. Fluorescent, mercury vapor, sodium, or amber vapor lights, or standard outdoor lights of the type used for security must be enclosed in a manner that directs the light in a specific area without causing a visual impairment to passing motorist or a nuisance to neighboring properties. The issue of whether a nuisance exists shall be determined by the Architectural Control Committee in its sole discretion. All exterior fixtures that are attached to the main Residence and any post-mounted exterior fixtures shall be of compatible design and materials of the Residence.

(a) **Lighting fixtures:** all outdoor lighting fixtures shall be shielded such that direct light rays from the lamp(s) are directed downward and do not cross property lines.

(b) **Night Lighting:** night lighting other than street lighting and entry area lighting is prohibited within any common area lot.

(c) **Recreation lights:** all outdoor lighting used for recreation purposes on any lot shall be turned off by 10:00 p.m.

(d) **Security Lighting:** all security lighting will only be approved by the Architectural Control Committee if the lighting is screened and is triggered by movement, sound, or heat and stays on for a time limited to no more than five minutes.

(e) **Holiday Lighting:** Exterior holiday lighting shall only be permitted when the lighting does not blink or flash. Exterior holiday lighting may be installed on the residence or on any Lot only between November 1st and January 15th of each year and must be removed immediately thereafter.

5.12 Front Yard Landscaping. Front Yard landscaping must be installed prior to occupancy unless a written variance is granted by the ACC due to weather conditions. At least Forty Percent (40%) of a Lot's Front Yard Area shall be improved with sod with the remaining portion of the Lot's Front Yard Area covered with groundcover plants, shrubbery, rocks or other landscape elements approved by the Architectural Control Committee. At least two common community trees (as defined in Exhibit A of the Design Guidelines) shall be used in the design of the front yard landscaping in accordance with the approval of the Architectural Control Committee. This approved tree shall be maintained by the Owner of the Lot and, in the event of the death or substantial destruction of the tree, the Owner shall immediately replace the tree at Owner's cost. Front Yard landscaping must include an automatic irrigation system.

5.13 Fences.

(a) **Private Fences:** All fences other than those constructed by Declarant, including the location and style, color, height, and function of such fence, must be approved in writing by the ACC prior to installation. All fences, other than the masonry wall installed by Declarant, shall be constructed of wood in accordance with the specifications set forth in Exhibit B Fence Design Specifications. All fences must be set back thirty feet (30') from the back of the curb of any Common Area roadway; no fencing shall be allowed within the front setback of any Lot. Fences must be installed prior to occupancy of any residence.

Some perimeter Lots within the Development will have wood or masonry fences installed by the Declarant in the manner determined by Declarant. Any wood fence installed by Declarant will be maintained by the Owner of the Lot upon which the fence is installed. Maintenance shall include repairs, cleaning, painting and staining as may be required from time to time. If owner fails or refuses to fully comply with this provision, then Declarant or the Association shall have the right to enter upon such Lot or Lots and perform such work as may be necessary to fulfill the requirements of this provision, charging the costs to the Owner. The association shall maintain the masonry wall as installed by Declarant.

5.14 Slope Stabilization: Each Lot Owner agrees to maintain any slopes located on said owner's lot or parcel and not change the grade in such a manner that it will not create a burden on the common area and/or an adjacent lot.

5.15 Construction Materials, Construction Debris. No portion of the Development shall be used for the storage of building materials other than in connection with construction projects approved in accordance with Article 8. All construction debris shall be picked up and deposited daily in an appropriate container.

5.16 Water Conservation: To the extent practicable, Owners shall incorporate water conservation elements into the overall design of residences and landscaping.

5.17 Soil and Water Conditions. Geotechnical investigations indicate that differential settlement conditions may exist between soils and rock in the Development. The Development also contains bedrock at varying depths and it is possible that the water table may be affected by these geologic features, subterranean hydrologic flows or differentials. Depending on the extent and location below finished subgrades, these soil and water conditions can have a detrimental effect on construction. Prior to any construction, Owners and builders are advised to conduct appropriate additional investigations into the soil, water and other conditions which may have an impact on such construction. Such investigations may be required prior to the issuance of a building permit.

5.18 Utilities. Underground utility lines shall be installed or extended to serve



each Lot in the Development. Any new utility extension or connection must be installed underground in accordance with Douglas County Code Section 20.220, Undergrounding of Utilities.

ARTICLE 6. ASSESSMENTS AND LIENS

6.1 Covenant of Owner. Each Owner of a Lot within the Development, by acceptance of a deed or other conveyance thereof, whether or not it shall be so expressed in such deed or conveyance, shall be deemed to have covenanted and agreed to pay to the Association: (i) Regular Assessments, (ii) Special Assessments, (iii) Reimbursement Assessments, and (iv) Enforcement Assessments levied by the Association as hereinafter provided, together with all Additional Charges. Such deed or conveyance shall be deemed to vest in the Association the right and power to initiate all actions and procedures as the Board shall deem necessary or appropriate for the collection of such Assessments and Additional Charges and for the enforcement of the liens hereinafter provided for.

Each Assessment levied by the Association under this article, together with all Additional Charges, shall be a separate, distinct, and personal debt and obligation of the Owner against whom it is assessed, and shall bind his or her heirs, devisees, personal representatives, successors, and assigns. Such obligation to pay Assessments and Additional Charges and the right and power of the Association to initiate all actions and procedures for collection shall run with the land, so that each successive Owner or Owners of Record of any Lot shall, in turn, become liable to pay all such Assessments and Additional Charges assessed during the time he or she is Record Owner of such Lot. After an Owner transfers of Record any Lot he or she owns, he or she shall not be liable for any Assessments levied thereafter with respect to such Lot. Such Owner shall remain personally liable, however, for all unpaid amounts due and owing at the time of transfer, together with Additional Charges accruing until time of collection. A Contract Seller of any Lot shall continue to be liable for all Assessments, late fees and Additional Charges until a conveyance by deed of such Lot is recorded.

6.2 Creation of Lien. As more particularly described in Section 116.3116 of the Act, each Assessment or fine levied by the Association pursuant to this Declaration, together with all Additional Charges, shall be a lien against an Owner's Lot from the time the Assessment or fine becomes due.

6.3 Purpose of Assessments. The Assessments levied by the Board shall be used exclusively for (i) managing and operating the Development, (ii) conducting the business and affairs of the Association, (iii) promoting the recreation, health, safety, welfare, benefit, and interests of the Owners and Residents of the Development, (iv) improving and maintaining the Common Elements and, to the extent provided for in the Governing Documents or by law, the Lots situated within the Development, (v) enforcing the Governing Documents, and/or (vi) otherwise benefiting the Owners.

6.4 Authority of the Board/Ratification by Members. The Board shall have the power and the duty to levy Regular and Special Assessments sufficient to meet the



Association's obligations under the Governing Documents and applicable law. Within thirty (30) days after adoption of any proposed budget for the Association, the Board shall provide a summary of the budget to all the Owners and shall set a date for a meeting of the Owners to consider ratification of the budget not less than fourteen (14) days nor more than thirty (30) days after mailing the summary. Unless at the ratification meeting a majority of the Owners of all Lots within the Properties vote to reject the budget the budget is ratified, whether or not a quorum is present. If the proposed budget is rejected, the periodic budget last ratified by the Owners must be continued until such time as the Owners ratify a subsequent budget proposed by the executive Board.

6.5 Regular Assessment.

(a) **Calculation of Estimated Requirement.** Not less than thirty (30) days nor more than sixty (60) days prior to the beginning of each fiscal year, the Board shall complete and distribute to all Owners an estimate of the net funds required by the Association for such fiscal year (including a reasonable amount allocated to contingencies and to a reserve fund for restoration, repair, and/or replacement of those components for which the Association is responsible and which must be repaired or replaced on a periodic basis) to manage, administer, operate, and maintain the Development; to conduct the affairs of the Association; and to perform all of the Association's duties in accordance with this Declaration.

(b) **Allocation of Regular Assessment.** The Board shall allocate and assess the amount of estimated required funds equally among the Lots within the Properties by dividing the amount by the number of Lots, so that each Lot bears an equal share.

(c) **Payment of Regular Assessments.** Unless the Board shall designate otherwise, Regular Assessments shall be levied on an annual basis and shall be paid in twelve (12) equal monthly installments during the fiscal year, and each installment shall be due and payable on the first (1st) day of each month.

(d) **Commencement of Regular Assessment.** Regular Assessments shall commence as to each Lot in the Development on the first (1st) day of the first (1st) month following the month in which the first close of escrow occurs for the sale of a Lot to a person other than the Declarant. Each Lot in the subdivision shall thereafter be subject to its share of the then established annual Regular Assessment. The first annual Regular Assessment shall be pro rated, if necessary, according to the number of months remaining in the fiscal year established in the Association's Bylaws.

6.6 Special Assessments.

(a) **Purpose of Special Assessments.** If at any time during any fiscal year the Regular Assessment proves inadequate for any reason, including nonpayment of any Owner's share thereof or the unexpected repair, replacement, or reconstruction of Improvements located in the Development, or if funds are

otherwise required for any authorized activity of the Association, the Board may levy a Special Assessment in the amount of such actual or estimated inadequacy or cost.

(b) **Allocation of Special Assessments.** Special Assessments shall be allocated, assessed among the Lots and paid in the same manner as Regular Assessments.

(c) **Special Individual Assessments.** Notwithstanding the foregoing, the Association shall be allowed to assess a Special Individual Assessment against specific Lot Owners for the limited purposes of enforcing or reimbursing the actions of the Architectural Control Committee under this Declaration.

6.7 **Reimbursement Assessments.** The Association shall levy a Reimbursement Assessment against any Owner and his or her Lot (i) if a failure by such Owner, or any person or pet for whom the Owner is responsible, to comply with any provision of the Governing Documents has necessitated or resulted in an expenditure of funds by the Association to deal with such lack of compliance or to bring such Owner or his Lot into compliance, or (ii) in the event that the Association has expended funds performing emergency repairs as authorized by this Declaration or for any other reasons specifically authorized by the provisions of this Declaration. A Reimbursement Assessment shall include any costs, including attorneys' fees, incurred by the Association, including costs of collecting from an Owner any amount which the Owner is obligated to pay to the Association. A Reimbursement Assessment shall be due and payable to the Association when levied.

6.8 **Enforcement Assessments.** The Board may levy an Enforcement Assessment (and any fine imposed by the Board in accordance with the provisions of the Governing Documents shall be deemed to be such an Enforcement Assessment), against any Owner for violation of any of the provisions of the Governing Documents. Any Enforcement Assessment shall be due and payable to the Association when levied.

6.9 **Failure to Fix Assessments.** The failure or omission by the Board to fix or levy any Regular Assessment provided for by the terms of this Declaration before the expiration of any fiscal year, for that fiscal year or the next fiscal year, shall not be deemed either a waiver or a modification in any respect of the provisions of this Declaration, or a release of any Owner from the obligation to pay Assessments or any installment thereof for that or any subsequent year, but the amount of the Regular Assessment fixed for the preceding fiscal year shall be the amount of the Regular Assessment for the ensuing fiscal year until a new Regular Assessment is levied.

6.10 **Offsets.** All Assessments levied by the Board shall be payable in the full amount specified, including any Additional Charges imposed as provided by the terms of this Declaration, and no offsets against any such amounts shall be permitted for any reason whatsoever, including without limitation a claim that the Association has failed to properly exercise its duties of maintenance or enforcement.



6.11 Delinquent Assessments. Any installment or other portion of an Assessment not paid within fifteen (15) days after its due date shall be delinquent and shall be subject to interest and late charges not to exceed the maximum rate permitted by law, as well as all other Additional Charges. The Board, on behalf of the Association, may enforce the payment of any delinquent Assessment plus Additional Charges by bringing an action at law against any Owner personally obligated to pay the same, or by foreclosing the lien against the Owner's Lot by judicial or non-judicial foreclosure, except as prohibited by law.

6.12 Late Charges. If any Assessment, whether regular or special, is not paid within fifteen (15) days after it is due, the Owner may be required by the Board to pay a late charge at such a rate as the Board may designate from time to time not to exceed eighteen percent (18%) or what is allowable under NRS 116 whichever is less.

6.13 Power of Sale. Except as provided in subsection (d), of this Section 6.13, the Association shall have the power to foreclose an Assessment lien by sale after:

(a) The Association has mailed by certified or registered mail, return receipt requested, to the Lot's Owner or successor in interest, at his address if known, and at the address of the Lot, a notice of delinquent assessment(s) which states the amount of the assessments and other sums which are due in accordance with Section 116.3116 of the Act, a description of the Lot against which the lien is imposed, and the name of the record owner of the Lot;

(b) Not less than thirty (30) days after the mailing of the notice of delinquent assessment, the Association or other person conducting the sale has executed and caused to be Recorded a notice of default and election to sell the Lot to satisfy the lien, which must be signed by the person designated by the Association for that purpose, or if no one is designated, by the president of the Association and contains the same information as the notice of delinquent assessment, but must also describe the deficiency in payment and the name and address of the person authorized by the Association to enforce the lien by sale; and

(c) The Lot's owner or his successor in interest has failed to pay the amount of the lien, including costs, fees and expenses incident to its enforcement, for ninety (90) days following the recording of the notice of default and election to sell. The period of ninety (90) days begins on the first (1st) day following the later of:

(i) The day on which the notice of default is Recorded at the Douglas County recorder; or

(ii) The day on which a copy of the notice of default is mailed by certified or registered mail, return receipt requested, to the Lot's Owner or successor in interest at the Owner's address if known, and at the address of the Lot.



(d) The Association may not foreclose a lien by sale for the Assessment of a fine for a violation of the Declaration, Bylaws, Rules or regulations of the Association, unless the violation is of a type that threatens the health, safety or welfare of the residents of the Properties.

6.14 Commencement of Foreclosure Proceedings. In order for the Association to commence foreclosure proceedings against an Owner's Lot, the Association shall comply with Sections 116.31162, 116.31163, 116.311635, 116.31164, 116.31166, and 116.31168 of the Act.

6.15 Certificate of Outstanding Balance. Within ten (10) days of receipt of a written request, the Association shall furnish to a Lot Owner a statement setting forth the amount of unpaid assessments against the Lot. If requested, the statement must be in recordable form. The statement is binding on the Association, its Board of Directors, and every Lot's Owner.

6.16 Priority. The lien securing each of the Assessments provided for under this article shall have priority as provided in Section 116.3116(2) of the Act.

6.17 Association Funds. All Association accounts shall be maintained in one or more banks or other depositories selected by the Board, which accounts shall be clearly designated as belonging to the Association. The Assessments collected by the Association shall be properly deposited into such accounts. All Association funds maintained in reserve accounts may not be withdrawn without the signatures of at least two members of the Board of Directors or the signatures of at least one member of the Board of Directors and one officer of the Association who is not a member of the executive Board.

6.18 Allocation of Expenses of Water Service. In the event and during such time as the Association is operating the Common Water Facilities, the operating system expenses of the Common Water Facilities shall be allocated to each Lot based on a fraction, the numerator of which is (1) and the denominator of which is the greater of (i) the number of approved lots on the date of recordation of this Declaration or (ii) the number of Lots which comprise the Property (including the Initial Property and any Annexable Property which is annexed pursuant to the provisions of this Declaration).

6.19 Waiver of Exemptions. Each Owner, to the extent permitted by law, does hereby waive, to the extent of any liens created pursuant to this article, the benefit of any homestead or exemption laws of the State of Nevada in effect at the time any Assessment or installment thereof becomes delinquent or any lien is imposed pursuant to the terms of this article.

6.20 Property Exempt From Assessments. The following property subject to this Declaration shall be exempt from the Assessments, Additional Charges, and liens created herein:

(a) All property dedicated to and accepted by the City, County, or other local

BK- 0106
PG- 1922
Page: 40 Of 71 01/09/2006
0665170

public authority and devoted to public use.

(b) Any Lot which is owned by the Association as a result of the Association having acquired such Lot through foreclosure. Such exemption shall be applicable only during the period in which the Association is Record Owner of such Lot.

(c) All Common Elements.

6.21 Deferred Assessments Payable by Declarant. The Declarant and the Association may enter into a subsidy agreement to set all or a portion of the Annual Assessment the Declarant is to fund as required hereunder until the Declarant's Control Termination date as provided in NRS 116.31038.

ARTICLE 7. MAINTENANCE OF PROPERTY

7.1 Association Responsibilities. The Association shall have the following maintenance responsibilities:

(a) Common Elements. The Association shall maintain, repair, and replace the Common Elements, keeping the same in good condition and repair.

(b) Other Association Property. The Association shall maintain, repair and replace all other real and personal property that may be acquired by the Association, keeping such property in good condition and repair.

7.2 Owner Responsibilities. Except as clearly and specifically made an Association responsibility pursuant to Section 7.1 above, each Owner shall be solely and exclusively responsible for the maintenance, repair and replacement of his or her Lot and all Improvements thereon, and shall keep the same in good and attractive condition and repair. Each Owner's obligations shall include, without limitation, the following:

(a) Residence and Other Buildings. Each Owner shall maintain, in good and attractive condition and repair, the Residence and other buildings located on his or her Lot.

(b) Landscaping. Each Owner shall maintain the landscaping on his or her Lot. The grass on each Lot shall be mowed on a regular basis. No weeds, underbrush or any other unsightly growth shall be permitted to grow or remain on any Lot. No refuse pile or unsightly object shall be permitted on any Lot. The Board is specifically empowered to adopt Rules regarding the care of landscaping on Lots including without limitation Rules governing the maximum height of grass, bushes and other landscaping elements. For all Lots within the Development, all front yard landscaping on a Lot shall be completed prior to occupancy unless an extension is granted in writing by the Board. The Architectural Control Committee may require that the Owner post a bond or cash



deposit to assure the faithful and timely installation of the landscape improvements, the amount of such deposit or bond being fixed by the Committee in its sole discretion. If a bond or cash deposit is posted, the Architectural Control Committee may nevertheless impose a deadline for completion of the landscape improvements and initiate appropriate enforcement actions if the Owner fails to complete the landscape work as agreed. Without limiting the foregoing, remedial action by the Association or the Architectural Control Committee may include exercise of the Association's rights of entry (see Section 7.6, below), installation of landscaping as approved by the Architectural Control Committee and recovering the cost of such work from the defaulting Owner as a Special Individual Assessment.

(c) **Fences.** Each Owner shall maintain, repair and replace the fences located on his or her Lot, keeping the same in good and attractive condition and repair. Some perimeter Lots within the Development will have wood or masonry fences installed by the Declarant in the manner determined by Declarant. Any Perimeter fence installed by the Declarant shall be maintained by the Owner of the Lot upon which the fence is installed, with the exception of the masonry wall as it applies to section 5.13(a) Maintenance shall include repairs, cleaning, painting and staining as may be required from time to time. Common fences shared by Lots shall be maintained in accordance with the following provisions:

(i) **General Rules of Law Apply.** Each fence which is placed on the dividing line between the Lots shall constitute a common fence. The general rules of law regarding common fences and liability for property damage due to negligence or willful acts or omissions shall apply thereto.

(ii) **Sharing of Repair and Maintenance.** The cost of maintenance and repair of a common fence shall be shared by the Owners who make use of the fence in proportion to such use.

(iii) **Destruction by Fire or Other Casualty.** If a common fence is destroyed or damaged by fire or other casualty, any Owner who has used the common fence may restore it, and if the other Owner thereafter makes use of the common fence, he or she shall contribute to the cost of restoration thereof in proportion to such use, without prejudice, however, to the right of any such Owners to call for a larger contribution from the others under any rule of law regarding liability for negligent or willful acts or omissions.

(iv) **Right to Contribution Runs With Land.** The right of any Owner to contribution from any other Owner under this section shall be appurtenant to and run with the land and shall pass to such Owner's successors in title.

(d) **Utility Connections.** Utility lines and connections, including without limitation, water, sewer, electrical, cable television, telephone and gas lines, which are located on, under, or over any Lot and which provide service to the



Residence or other Improvements located upon such Lot, shall be maintained, repaired and replaced by the Owner of such Lot or by the utility company providing such service.

(e) **Storm Water Drainage Systems.** Each Owner shall be responsible for maintaining, repairing and replacing any storm water drainage system located on such Owner's Lot.. There shall be no interference with or obstruction of the established surface drainage pattern(s) over any Lot within the Properties, unless an adequate alternative provision is made for proper drainage. Any alteration of the established drainage pattern must at all times comply with all applicable local governmental ordinances. For the purpose hereof, "established" drainage is defined as the drainage which exists at the time the overall grading of any Lot is completed by Declarant. Each Owner shall maintain, repair, and replace and keep free from debris or obstructions the drainage channels, systems, and devices, if any, located on his Lot, except those for which a public authority or utility is responsible.

7.3 Compliance with Architectural Provisions. An Owner's right and responsibility for maintaining, repairing or replacing any portions of his or her Lot, including landscaping, shall be subject to any applicable provisions of the Governing Documents relating to landscaping and architectural control, including Article 8.

7.4 Owner Failure to Maintain. The Board shall have the absolute discretion to determine whether any maintenance, repair, or replacement which is the responsibility of an Owner is necessary to preserve the appearance and value of the property comprising the Development, or any portion thereof, and may notify an Owner of the work the Board deems necessary. In the event an Owner fails to perform such work within thirty (30) days after notification by the Board to the Owner, the Board may, after written notice to the Owner and the right of a hearing before the Board, enter upon any Lot and cause such work to be done and charge the cost thereof to the Owner as a Reimbursement Assessment.

7.5 Owner Liability. In the event the need for any maintenance, repair, or replacement by the Association is caused by the willful or negligent act or omission of an Owner, members of any Owner's household, or an Owner's tenants, Contract Purchaser, guests, invitees, or household pets, the cost of such maintenance, repair, or replacement, including the cost of materials, labor, supplies, and services shall be charged to, and paid by, such Owner in the form of a Reimbursement Assessment.

7.6 Authority for Entry of Lot. The Association or its agents may enter any Lot without liability to any owner for purpose of enforcing any of the provision of this declaration, whenever such entry is necessary, in the Board's sole discretion, in connection with the performance of any maintenance, repair, construction, or replacement for which the Association is responsible or which it is authorized to perform, including without limitation the authorization provided in Section 7.4. Although under no obligation to do so, the Board, in its complete and sole discretion, may enter or may authorize the Association's agents to enter any Lot to effect emergency repairs where



such repairs are necessary for safety reasons or to prevent or discontinue damage to the entered Lot, any other Lot or the Common Elements. The cost of performing any such emergency repairs shall be charged to the Owner as a Reimbursement Assessment. Such entry shall be made with as little inconvenience to the Residents as practicable and only upon reasonable advance written notice of not less than twenty-four hours, except in emergency situations.

7.7 Association Liability. The Association shall not be responsible or liable for any maintenance, repair, or replacement of a Lot or any Improvement thereon, except to the extent that the need for such maintenance, repair, or replacement results from the negligence or fault of the Association, its employees, contractors, or agents.

7.8 Board Discretion. The Board shall have the discretion to determine the manner, method, extent and timing of the performance of any and all maintenance, repair and replacement obligations imposed upon the Association this article.

7.9 Cooperative Maintenance Obligations. To the extent necessary or desirable to accomplish the Association's maintenance and repair obligations hereunder, individual Owners shall cooperate with the Association and its agents and maintenance personnel in the prosecution of its work.

ARTICLE 8 ARCHITECTURAL CONTROLS

8.1 Submission of Plans and Specifications. Except for Improvements made or constructed by or on behalf of the Association, no Improvements including without limitation landscaping, Residences, buildings, fences, walls, obstructions, balconies, screens, patio covers, awnings, or other structures of any kind, shall be commenced, located, erected, painted, or maintained within the Development, nor shall any exterior addition to or change or alteration therein be made, until the plans and specifications showing the nature, kind, shape, color, height, size, materials, and location of the same shall have been submitted to and approved in writing by the Architectural Control Committee as to (i) quality of workmanship and design, (ii) harmony of external design in relation the nature and character of the Development and the Improvements thereon, and (iii) location in relation to surrounding structures, topography, finished grade elevation. Notwithstanding this section, and provided that the existing color and finish were approved by the Architectural Control Committee in the first instance, an Owner may repaint and refinish the exterior of the Improvements on his or her Lot in an identical color and finish without the approval of the Architectural Control Committee.

8.2 Establishment of Architectural Control Committee. The Board shall appoint an Architectural Control Committee ("ACC") consisting of three Members, who shall serve at the pleasure of the Board. The Board shall have the power, in its complete discretion and either with our without cause, to remove any member of the ACC. In the event of death, resignation or removal of any member of the ACC, the Board shall have the full authority to designate a successor. If at any time there shall not be a duly-constituted ACC, the Board shall exercise the functions of the ACC in accordance with



the terms of this article.

8.3 Duties. It shall be the duty of the ACC to consider and act upon proposals or plans submitted to it, to perform other duties delegated to it by the Board, and to carry out all other duties imposed upon it by this Declaration.

8.4 Meetings. The ACC shall meet as necessary to properly perform its duties hereunder. Every act done or decision made by a majority of the members of the ACC shall be the act or decision of the ACC. The ACC shall keep and maintain a record of all actions taken by it at such meetings or otherwise. The ACC and its members shall be entitled to reimbursement for reasonable out-of-pocket expenses incurred by them in the performance of any ACC function.

8.5 Architectural Design Guidelines. The ACC may, from time to time, and subject to the Board's approval, adopt, amend, and repeal rules and regulations to be known as Architectural Design Guidelines. The Architectural Design Guidelines shall interpret and implement the provisions of this article by setting forth the standards and procedures for ACC review and guidelines for architectural design, placement of Residences and other structures, color schemes, exterior finishes and materials, and similar features which are recommended for use in the Development; provided, however, that the Architectural Design Guidelines shall not be derogatory to the minimum standards required by this Declaration. The Architectural Design Guidelines may also impose limits on the days and hours of construction and impose any other restrictions and regulations which the Board deems appropriate to limit the impact of construction activities on the Residents. In its discretion, and subject to the Board review, the ACC may grant variances from specific requirements of the Architectural Design Guidelines subject to such terms and conditions as it deems appropriate.

8.6 Application. Any Owner proposing to perform any work of any kind whatever, which requires prior approval pursuant to this article, shall apply for approval by notifying the Association, in writing, of the nature of the proposed work and furnishing such information and documentation as the ACC or Board may require, including without limitation samples of proposed paints in such sizes and formats as the Committee or the Board may deem appropriate. In accordance with the provisions in Article 10, and in addition to any other remedies the Association may have, the Board may impose a fine against any Owner who fails to submit an application, and obtain the required approval thereof, prior to proceeding with any Improvement for which approval is required pursuant to this article. Except as provided in the last sentence of Section 8.1, any Owner who paints his or her Residence or any other Improvement without first submitting an application and obtaining the approval required by this article may be required, in the Board's discretion, to repaint the Residence or Improvement.

8.7 Fees. The ACC may charge a reasonable fee or fees for its review of architectural or landscaping applications, drawings, plans, and specifications which may include the cost of retaining outside consultants including but not limited to architects, engineers, soils experts, or contractors and the cost of cleaning Common Elements and streets and removing construction debris. The ACC is authorized to contract with a



licensed management company to provide administrative and cleaning services. In the event that the ACC elects to use a management company, the fees charged under this Section may be paid directly to the management company that provides the services.

8.8 Construction Deposit. Upon approval of any residential construction by the ACC in accordance with this Article 8, the Owner shall deposit with the Association the sum of Two Thousand Five Hundred Dollars (\$2,500.00) (the "Deposit") to assure general clean-up of the construction site and any corrective work to the Common Elements, streets or sidewalks as may be required as a result of the Owner's construction activities. The Deposit will be placed in the Association's operating account and will be non-interest bearing. Upon the Owner's notification to the Association that the Owner has completed the construction of the approved Improvements and has completed all corrective work, if any, the ACC shall inspect and verify completion of the work and any required corrective work in accordance with Section 8.15 below. Upon such inspection and verification the ACC shall either approve the work or notify the Owner in writing of any additional required corrective action. Upon final approval, the ACC shall cause the Deposit to be returned to the Owner. If the Owner fails or refuses to complete any required corrective work the Association shall complete or have completed such corrective work at the Owner's expense and thereafter shall return the Deposit to the Owner less the cost of the corrective work as incurred by the Association. In the event that the corrective work costs more than the amount of the Deposit the Owner shall be liable for any amount due in excess of the Deposit.

8.9 Grant of Approval. The ACC shall grant the requested approval only if:

(a) The Owner shall have complied with the provisions of Section 8.1, paid all required fees and complied fully with all applicable federal, state and local laws, regulations and ordinances, insofar as the same are applicable and as the same may hereafter be amended from time to time.

(b) The ACC shall find that the plans and specifications conform to both (i) this Declaration, and (ii) the Architectural Design Guidelines in effect at the time such plans were submitted to the Committee, unless a variance is granted from such Architectural Rules.

(c) The ACC shall determine that the proposed Improvements would be consistent with the standards of the Development and the purposes of this Declaration as to quality of workmanship, design and materials, as to harmony of exterior design with the existing structures, and as to location with respect to topography and finished grade elevations.

8.10 Form of Approval. All approvals and denials of requests for approval shall be in writing. The ACC may approve a request for approval subject to the Owner's consent to any modifications made by the ACC. If the Owner does not consent to the modifications, the request for approval shall be deemed denied in its entirety.

8.11 Time for ACC Action. Any request for approval which has not been acted



upon by the ACC within forty-five (45) days from the date of receipt thereof by the ACC shall be deemed approved. The Owner requesting approval shall have the burden of establishing the date of receipt of the request for approval by the ACC by evidence in the form of either a copy of such request for approval date-stamped by the Association or by a return receipt provided by the U. S. Postal service acknowledging that such request for approval was delivered to the Association.

8.12 Board Review. Owner's receiving a denial from the ACC shall have ten (10) days from the date of the denial to appeal the denial to the Board in writing. The Board may affirm, reverse or modify the decision in its discretion and in accordance with the provisions of the Governing Documents and shall so notify the applicant within thirty (30) days following the Board's decision.

8.13 Commencement. Upon receipt of approval pursuant to this article, the Owner shall, as soon as practicable, satisfy all conditions thereof and diligently proceed with the commencement and completion of all installation, construction, reconstruction, refinishing, alterations, and excavations pursuant to such approval, commencement to occur, in all cases, within ninety (90) days from the effective date of such approval or upon such later date as the Board may in its discretion designate. If the Owner shall fail to comply with this section, any approval previously given shall be deemed revoked unless the Board, upon written request of the Owner made prior to the expiration of the time for commencement, extends the time for such commencement. No such extension shall be granted except upon a finding by the Board that there has been no change in the circumstances upon which the original approval was granted.

8.14 Completion. The Owner shall, in any event, complete the installation, construction, reconstruction, refinishing, or alteration of any Improvement, within one (1) year after commencing construction thereof (or in the case of projects under construction when this Declaration is Recorded, within one (1) year after the date of Recordation), except and for as long as such completion is rendered impossible or would result in great hardship to the Owner due to strikes, fires, national emergencies, natural calamities, or other supervening forces beyond the control of the Owner or his agents. If an Owner fails to comply with this section, the Board shall proceed in accordance with the provisions of Section 8.18, below, as though the failure to complete the Improvements was a non-compliance with approved plans.

8.15 Inspection. Inspection of work and correction of defects therein shall proceed as follows:

- (a) Upon the completion of any installation, construction, reconstruction, alteration, or refinishing of the exterior of any Improvements, or upon the completion of any other work for which approved plans are required under this article, the Owner shall give written notice thereof to the ACC.
- (b) Within sixty (60) days after the receipt of such written notice, the ACC, or its duly authorized representative, may inspect such Improvement to determine whether it was installed, constructed, reconstructed, altered, or refinshed to

substantial compliance with the approved plans. If the ACC finds that such installation, construction, reconstruction, alteration, or refinishing was not done in substantial compliance with the approved plans, it shall notify the Owner in writing of such non-compliance within such sixty (60) day period, specifying particulars of non-compliance and shall require the Owner to remedy such non-compliance.

(c) If the Owner shall have failed to remedy such non-compliance upon the expiration of thirty (30) days from the date of such notification, the ACC shall notify the Board in writing of such failure. The Board shall then set a date on which a hearing before the Board shall be held regarding the alleged non-compliance. The hearing date shall be not more than thirty nor less than fifteen (15) days after notice of the non-compliance is given to the Board by the ACC. Notice of the hearing date shall be given at least ten (10) days in advance thereof by the Board to the Owner, to the ACC and, in the discretion of the Board, to any other interested party.

(d) At the hearing the Owner, the ACC and, in the Board's discretion, any other interested person, may present information relevant to the question of the alleged non-compliance. After considering all such information, the Board shall determine whether there is a non-compliance, and, if so, the nature thereof and the estimated cost of correcting or removing the same. If non-compliance exists, the Board shall require the Owner to remedy or remove the same within a period of not more than forty-five (45) days from the date of the Board's ruling. If the Owner does not comply with the Board's ruling within such period or within any extension of such period as the Board, in its discretion, may grant, the Board, at its option, may either remove the non-complying Improvement or remedy the non-compliance and all expenses incurred in connection therewith shall be assessed against the Owner as a Reimbursement Assessment.

(e) If, for any reason, the ACC fails to notify the Owner of any non-compliance within sixty (60) days after receipt of a notice of completion from the Owner, the Improvement shall be deemed to be in accordance with the approved plans. The Owner shall have the burden of establishing the date of receipt of the notice of completion by the ACC by evidence in the form of either a copy of such notice date-stamped by the Association's office or by a return receipt provided by the U. S. Postal service acknowledging that such notice was delivered to the Association.

(f) Any member of the ACC or the Board may enter upon any Lot, or structure thereon, at any reasonable time prior to the issuance of a valid Certificate of Occupancy for the purpose of inspection.

8.16 Preliminary Approval. Any Owner proposing to construct Improvements requiring the prior approval of the ACC may apply to the ACC for preliminary approval by submission of preliminary drawings of the proposed Improvements in accordance with the Architectural Design Guidelines. The purpose of the preliminary approval procedure



is to allow an Owner proposing to make substantial Improvements an opportunity to obtain guidance concerning design considerations before expending substantial sums for plans and other exhibits required to apply for final approval. Application for preliminary approval shall be considered and disposed of as follows:

(a) Within forty-five (45) days after proper application for preliminary approval, the ACC shall consider and act upon such request. However, notwithstanding any other provision of this Declaration, no failure to act upon an application for preliminary approval shall be deemed to be an approval of such application. The ACC shall grant the approval only if the proposed Improvement, to the extent its nature and characteristics are shown by the preliminary application, would be entitled to a final approval on the basis of a full and complete application. In granting or denying approval, the ACC may give the applicant such directions concerning the form and substance of the final application for approval as it may deem proper or desirable for the guidance of the applicant.

(b) Any preliminary approval granted by the ACC shall be effective for a period of ninety (90) days from the date of the issuance thereof or such longer period as may be approved by the ACC. During such period, any application for final approval which consists of proposed Improvements in accordance with the provisions of the preliminary approval, and is otherwise acceptable under the terms of this Declaration, shall be approved by the ACC.

(c) In no event shall any preliminary approval be deemed to be an approval authorizing installation or construction of the subject Improvements.

8.17 Non-Waiver. The approval by the ACC of any plans, drawings, or specifications for any work done or proposed, or for any other matter requiring the approval of the ACC under this Declaration, shall not be deemed to constitute a waiver of any right to withhold approval of any similar plan, drawing, specification, or matter subsequently submitted for approval.

8.18 Estoppel Certificate. Within thirty (30) days after written demand is delivered to the Association by any Owner, and upon payment to the Association of a reasonable fee (as fixed from time to time by the Board), the Board shall Record an estoppel certificate, if permitted by the County, certifying (with respect to any Lot of such Owner) that as of the date thereof, either: (i) all Improvements made and other work completed by such Owner comply with this Declaration, or (ii) such Improvements or work do not so comply, in which event the certificate shall also identify the non-complying Improvements or work and set forth with particularity the basis of such non-compliance. Any purchaser from the Owner, or from anyone deriving any interest in a Lot through him, shall be entitled to rely on such certificate with respect to the matters therein set forth, such matters being conclusive as between the Association and all Owners and such persons deriving any interest through them.

8.19 Notice of Noncompliance. If any Improvements installed within the

Development are not in conformance with this Declaration, the Association is authorized to Record a Notice of Noncompliance, if permitted by the County. The Notice of Noncompliance shall provide: (i) a legal description of the Lot affected, (ii) the name of the record Owner as most recently reported to the Association, and (iii) a description of the general nature of the noncompliance. If and when such Lot is brought into compliance with this Declaration, as determined by the Board, the Association shall issue and, if permitted by the County, Record an estoppel certificate in accordance with Section 8.17.

8.20 Liability. Neither the Board, the ACC nor any member or representative thereof shall be liable to the Association or to any Owner for any damage, loss, or prejudice suffered or claimed on account of: (i) the approval or disapproval of any plans, drawings, and specifications, whether or not defective; (ii) the construction or performance of any work, whether or not pursuant to approved plans, drawings, and specifications; (iii) the development of any property within the Development; (iv) the execution and filing of an estoppel certificate pursuant to Section 8.17, whether or not the facts therein are correct; provided, however, that the ACC, the Board or any member or representative thereof has acted in good faith on the basis of such information as may be possessed by it or him; or (v) the execution and filing of a notice of noncompliance pursuant to Section 8.18, whether or not the facts therein are correct; provided, however, that the ACC, the Board or any member or representative thereof has acted in good faith on the basis of such information as may be possessed by it or him. Without in any way limiting the generality of the foregoing, the ACC, the Board or any member or representative thereof, may, but is not required to, consult with or hear the views of the Association or any Owner with respect to any plans, drawings, specifications, or any other proposal submitted to the ACC. Every purchaser, by acquiring title to a Lot or portion thereof agrees not to bring any action or suit against the Board, the ACC, or their members or representatives seeking to recover any such damages.

8.21 Compliance with Governmental Requirements. The application to the Association, and the review and approval of any proposals, plans, or other submittals, shall in no way be deemed to be satisfaction of or compliance with any building permit process or any other governmental requirements, the responsibility for which lies solely with the respective Owner, nor shall it constitute the assumption of any responsibility by or impose any liability on the Board, the ACC, or their members as to the accuracy, efficacy, or sufficiency of such proposals, plans or other submittals.

ARTICLE 9. EASEMENTS

9.1 Easements in General. In addition to all easements reserved and granted on the Subdivision Map and the easements specified in this Article 9, there are hereby specifically acknowledged, reserved and granted for the benefit of the Declarant, Lots and the Owners in common and for each Lot and Owner severally, and for the Association, as their respective interests shall exist, the easements and rights of way as particularly identified in this article.



9.2 Utility Easements. Easements over and under the Development or any portion thereof for the installation, repair, maintenance, and replacement of (i) electric, telephone, water, irrigation, gas, and sanitary sewer lines, meters, and facilities, (ii) cable lines and facilities, (iii) drainage facilities, (iv) walkways, and (v) landscaping, as shown on the Subdivision Map, and as may be hereafter required or convenient to service the Development, are reserved by and shall exist in favor of the Association, and the Declarant, together with the right to grant and transfer the same. Specifically, the County requires that a seven and one-half foot (7.5') public utility easement be reserved along all road frontages and a five foot (5') public utility easement be reserved along the side and rear property lines of all Lots. The Association shall maintain all utility installations located in the Common Elements except for those installations maintained by utility companies, public, private, or municipal.

9.3 Easements Granted by Board. The Board shall have the power to grant and convey to any person or entity easements and rights of way, in, on, over, or under the Common Elements for the purpose of (i) constructing, erecting, operating, or maintaining thereon, therein, or thereunder overhead or underground lines, cables, wires, conduits, or other devices for electricity, cable television, power, telephone, public sewers, storm drains and pipes, water systems, sprinkling systems, water, heating and gas lines or pipes, and any similar public or quasi-public improvements or facilities, (ii) authorized parking, maintenance and vehicular and pedestrian traffic and access, and (iii) for any other purposes deemed by the Board to be appropriate and not inconsistent with the purposes and interests of the Association. Each purchaser, in accepting a deed to a Lot, expressly consents to such easements and rights of way. No such easements may be granted if they would unreasonably interfere with the use, occupancy, or enjoyment by an Owner or Resident of his or her Lot without the consent of the affected Owner of the Lot.

9.4 General Association Easements for Maintenance, Repair and Replacement. The Association shall have an easement in, on, over or under every Lot as reasonably necessary to (i) maintain and repair the Common Elements, (ii) perform maintenance upon a Lot which is not performed by its Owner as provided by Sections 7.2, 7.4 and 7.6, and (iii) otherwise perform its obligations under this Declaration.

9.5 Encroachment Easements. Each Lot is hereby declared to have an easement over adjoining Lots and Common Elements for the purpose of accommodating any encroachment due to fences or walls which are built in accordance with the original design, plans and specifications of Declarant, and due to engineering errors, errors in original construction, settlement or shifting, or similar causes. There shall be valid easements for the maintenance of said encroachments as long as they shall exist, and the rights and obligations of the Owner shall not be altered in any way by said encroachment, settlement or shifting; provided, however, that in no event shall a valid easement for encroachment be created in favor of an Owner or Owners if said encroachment occurs due to the willful misconduct of said Owner or Owners. In the event a structure is partially or totally destroyed, and is repaired or rebuilt, the Owners of each adjoining Lot agree that minor encroachments of the adjoining Lots shall be permitted and that there shall be valid easements for the maintenance of said encroachments so long as they shall exist but in no event for a period of more than twenty-four (24) months from the date of



the partial or total destruction.

9.6 Utility Maintenance and Repair Easements. The following shall apply with respect to utility maintenance and repair easements:

(a) Owners' Easements. Wherever sanitary sewer connections or water connections or electricity, gas or telephone, television lines or drainage facilities are installed within the Development, which connections, lines or facilities, or any portion thereof, lie in or upon Lots owned by other than the Owner of the Lot served by said connections, the Owners of any Lots served by said connections, lines or facilities shall have the right, and are hereby granted an easement to the full extent necessary therefore, to enter such Lots or to have utility companies enter therein, or any portion thereof, to repair, replace and generally maintain said connections as and when the same may be necessary. Wherever sanitary sewer house connections and/or water Residence connections or electricity, gas, telephone or cable lines or drainage facilities are installed within the Development, which connections serve more than one Lot, the Owner of each Lot served by said connections shall be entitled to the full use and enjoyment of such portions of said connections as service his Lot.

(b) Utility Companies' Easements. All utility companies having easements on the property covered by this Declaration shall have easements for cleaning, repairing, replacing, and otherwise maintaining or causing to be maintained service in all underground utility lines, including, when reasonably necessary, the entry into an improvement constructed upon a Lot for uncovering any such lines. Any Owner or utility company exercising the rights granted in this section shall be obligated to restore the Lot and the Residence entered to substantially its former condition.

9.7 Declarant's Easements. The Declarant shall have an easement in, on, over or under every Lot and Common Element as reasonably necessary to (i) develop the project and construct improvements on the Properties, Lots and Common Elements, (ii) conduct sales and marketing activities within the Development, and (iii) otherwise perform its obligations under this Declaration

ARTICLE 10. ENFORCEMENT

10.1 Violations as Nuisance. Every act or omission constituting or resulting in a violation of any of the provisions of the Governing Documents shall be deemed to constitute a nuisance. In addition to any other remedies which may be available, such nuisance may be abated or enjoined by the Association, its officers, the Board or by any Owner. The Board shall not be obligated to take action to abate or enjoin a particular violation if, in the exercise of its discretion, the Board determines that acting to abate or enjoin such violation is not likely to foster or protect the interests of the Association and its Members as a whole.

10.2 Violation of Law. Any violation of a state, municipal or local law,



0656738

Page: 51 Of 68

BK- 1005
PG- 717
10/03/2005

BK- 0106
PG- 1934
01/09/2006

0665170 Page: 52 Of 71

ordinance or regulation pertaining to the ownership, occupancy, or use of any property within the Development is hereby declared to be a violation of this Declaration and subject to any and all of the enforcement procedures set forth herein.

10.3 Owners' Responsibility for Conduct and Damages. Each Owner shall be fully responsible for informing members of his or her household and his or her tenants, Contract Purchasers, contractors and guests of the provisions of the Governing Documents, and shall be fully responsible for the conduct, activities, any Governing Document violation of any of them, and for any damage to the Development or the Association resulting from the negligent or intentional conduct of any of them or any household pets. If a Lot is owned jointly by two or more persons, the liability of each Owner in connection with the obligations imposed by the Governing Documents shall be joint and several.

10.4 No Avoidance. No Owner may avoid the burdens or obligations imposed by the Governing Documents through non-use of any Common Elements facilities or by abandonment of his or her Lot.

10.5 Rights and Remedies of the Association.

(a) Rights Cumulative. The Association, its Directors, Officers, or agents, and any Owner shall have the right to enforce any and all provisions of the Governing Documents by any proceeding at law or in equity, or through the use of such other remedies as are available and deemed appropriate by the Board. Each remedy provided is cumulative and not exclusive.

(b) Member Not In Good Standing. Upon a determination by the Board of Directors, after prior notice to the affected Member and an opportunity for a hearing, that such Member has violated any provision of the Governing Documents including a failure to pay any Assessment when due, the Board shall give notice in writing to such Member that he or she is deemed not to be a Member in Good Standing. Such Member shall be deemed to remain in that status until such time as the Board shall determine in writing that the violation which resulted in the Board's determination has been cured or remedied or, on some other basis as in the judgment of the Board is just and proper, that such Member shall again be deemed to be a Member in Good Standing of the Association. Such Member shall be so notified in writing with a copy given to the Secretary.

(c) Imposition of Sanctions. In the event of a breach or infraction of any provision of the Governing Documents by an Owner, members of an Owner's household, or his or her tenants, Contract Purchasers, contractors, guests, pets or invitees, the Board shall have the power to impose sanctions against the Owner. Such sanctions may include, without limitation, the imposition of fines and/or the suspension of an Owner's rights as a Member, including an Owner's voting rights or an Owner's right to use the community facilities on the Common Elements; provided, however that the Board shall not impair an Owner's right to vehicular

and pedestrian ingress and egress to or from his or the Lot, including any area used for approved parking. Except as provided below, imposition of sanctions shall be effective only after the Board has held a hearing as provided in the Bylaws. The payment of any such fine may be enforced as an Enforcement Assessment as well as in any manner permitted by law. Further, each Owner shall be obligated to pay Reimbursement Assessments levied by the Board for reimbursement of any costs incurred by the Association relating to violation of any provisions of the Governing Documents by such Owner, members of such Owner's household, or his or her tenants, Contract Purchasers, contractors, guests, pets or invitees.

(d) **Inadequacy of Legal Remedy.** Except for the non-payment of any Assessments, it is hereby declared that a remedy at law to recover damages for a default in the performance of any of the terms and provisions of any of the Governing Documents or for the breach or violation of any such provisions is inadequate and that the failure of any Owner or a member of the household of any Owner or an Owner's tenants, guests, or household pets or any other occupant or user of any of the property within the Development to comply with any provision of the Governing Documents may be enjoined in any judicial proceedings initiated by the Association, its Officers or Board of Directors, or by any Owner or by their respective successors in interest.

(e) **Limitation on Disciplinary Rights.** The Association shall not have the power and authority to cause a forfeiture or abridgment of a Member's right to the full use and occupancy of his or her Lot as the result of the failure by such Owner, members of such Owner's household, or his or her tenants, guests, invitees or household pets to comply with any provision of the Governing Documents, except where such forfeiture or abridgment is the result of the judgment of a court of competent jurisdiction, a decision arising out of an arbitration proceeding, or a foreclosure or sale under private power of sale for failure of such Owner to pay Assessments levied by the Association pursuant to Article 6 of this Declaration. The provisions of this subsection shall not affect the Association's right to impose fines or monetary penalties or to suspend an Owner's membership rights, as provided in the Governing Documents.

(f) **Limitation on Commencing Civil Actions.** Except for civil actions commenced by the Association to enforce the Governing Documents, including the payment of Assessments, or to proceed with a counterclaim, the Association may commence a civil action only after providing at least twenty-one (21) calendar days notice of a meeting, at which an Absolute Majority of the Members consent to the filing of the civil action. At least ten (10) days before the meeting seeking consent to the filing of the civil action, the Association shall provide a written statement to all Lot Owners that includes: (i) a reasonable cost estimate of the civil action, including reasonable attorneys' fees; (ii) an explanation of the potential benefits of the civil action and the potential adverse consequences if the Association does not commence the action or if the action is not favorable to the Association; and (iii) all disclosures that are required to be made upon the sale of



the Property.

10.6 Disciplinary Rules. The Board or a committee appointed by the Board for that purpose may adopt rules and regulations that further elaborate upon and refine procedures for conducting disciplinary proceedings and otherwise imposing sanctions upon Members of the Association for violation of provisions of the Governing Documents. Such rules, when approved and adopted by the Board, shall be deemed to be a part of the Association Rules provided for in, and constituting a part of, the Governing Documents.

10.7 Emergency Situations. The following shall constitute emergency situations: (i) an immediate and unreasonable infringement of or threat to the safety or peaceful enjoyment of Residents of the Development, (ii) a traffic or fire hazard, or (iii) a threat of material damage to or destruction of the Development or any portion thereof. Notwithstanding any other provisions of the Governing Documents, under circumstances involving conduct that constitutes an emergency situation, the Association may undertake immediate corrective action. Hearings with respect to such corrective action shall be held following the corrective action in accordance with the Bylaws.

10.8 Non-Waiver. Failure to enforce any provision of the Governing Documents at any time shall not be deemed a waiver of the right to do so thereafter with respect to the same or any other violation of any provision of the Governing Documents.

10.9 Notices. Any notices required or given under this article shall, at a minimum, set forth the date, time, and location of any hearing, a brief description of the act or omission constituting the alleged violation of the Governing Documents, a reference to the specific Governing Document provision or provisions alleged to have been violated, and the sanction, disciplinary action, or other enforcement action being contemplated by the Board, if any. The notice shall be in writing and may be given by any method reasonably calculated to give actual notice to the affected Member; provided, however, that if notice is given by mail, it shall be sent by first-class mail, postage prepaid, sent to the most recent address for the affected Member as shown on the records of the Association.

10.10 Costs and Attorneys' Fees. In the event the Association shall take any action to enforce any of the provisions of the Governing Documents or shall determine that any Member or members of his or her household or his or her tenants, Contract Purchasers, guests, invitees or household pets have violated any provision of the Governing Documents, and whether or not legal or judicial proceedings are initiated, the prevailing party shall be entitled to recover the full amount of all costs incurred, including attorneys' fees, in responding to such a violation and/or in enforcing any Governing Document provision. The remedies of the Association to recover the amount of such costs and attorneys' fees shall include, without limitation, the imposition of a Reimbursement Assessment as provided in this Declaration.

10.11 Indemnification. Each Owner, by acceptance of his or her deed, agrees for himself or herself and for the members of his or her household, his or her Contract



Purchasers, tenants, guests or invitees, to (i) indemnify each and every other Owner for, (ii) hold each and every other Owner harmless from, and iii) to defend each and every other Owner against, any claim of any person for personal injury or property damage occurring within the Lot of such Owner, except that such Owner's liability may be diminished to the extent that the injury or damage occurred by reason of the negligence of any other Owner or person temporarily visiting in such Lot or is fully covered by insurance.

ARTICLE 11. INSURANCE

11.1 Types of Insurance Coverage. The Association shall, at the discretion of the Board of Directors but in conformance with the requirements of the Act, purchase, obtain and maintain, with the premiums therefore being paid out of Common Funds, the following types of insurance, if and to the extent they are available at a reasonable premium cost:

(a) **Property Insurance.** The Association shall obtain and maintain a master or blanket policy of property insurance, written on all risk, replacement cost basis, on all Common Area. The insurance shall be kept in full force and effect at all times and the full replacement value of the insured property shall be re-determined on an annual basis. Depending on the nature of the insured property and the requirements, if any, imposed by institutional Mortgagees having an interest in such property, the policies maintained by the Association pursuant to this section shall contain an agreed amount endorsement or a contingent liability from operation of building laws endorsement or the equivalent, an extended coverage endorsement, vandalism, malicious mischief coverage, a special form endorsement and a clause to permit cash settlements for full insurable value in case of partial destruction. The policies required hereunder shall name as insured the Association and all Mortgagees as their respective interests may appear. The policies may contain a loss payable endorsement in favor of the trustee described below.

(b) **General Liability Insurance.** To the extent such insurance is reasonably obtainable, a policy of comprehensive general liability insurance naming as parties insured the Association, each member of the Association Board of Directors, any manager, the Owners and occupants of Lots, and such other persons as the Board may determine. The policy will insure each named party against any liability incident to the ownership and use of the Common Area and any area of the Development that the Association is obligated to maintain, and such policy shall include, if obtainable, a cross-liability or severability of interest endorsement insuring each insured against liability to each other insured. The limits of such insurance shall not be less than One Million Dollars (\$1,000,000.00) covering all claims for death, personal injury and property damage arising out of a single occurrence. Such insurance shall include coverage against water damage liability, liability for non-owned and hired automobiles,



liability for property of others and any other liability or risk customarily covered with respect to common interest development projects similar in construction, location, facilities, and use.

(c) **Director's and Officer's Liability Insurance.** To the extent such insurance is reasonably obtainable the Association shall maintain individual liability insurance for its directors and officers providing coverage for negligent acts or omissions in their official capacities. The minimum coverage of such insurance shall be at least One Million Dollars (\$1,000,000.00).

(d) **Additional Insurance and Bonds.** To the extent such insurance is reasonably obtainable, the Association may also purchase with Association funds such additional insurance and bonds as it may, from time to time, determine to be necessary or desirable, including, without limiting the generality of this section, demolition insurance, flood insurance, earthquake insurance, and workers' compensation insurance. The Board shall also purchase and maintain fidelity bonds or insurance in an amount not less than one hundred percent (100%) of each year's estimated annual operating expenses and shall contain an endorsement of any person who may serve without compensation. The Board shall purchase and maintain such insurance on personal property owned by the Association and any other insurance, including directors' and officers' liability insurance, that it deems necessary or desirable.

11.2 **Coverage Not Available.** In the event any insurance policy, or any endorsement thereof required by Section 12.1, is for any reason unavailable, then the Association shall obtain such other or substitute policy or endorsement as may be available which provides, as nearly as possible, the coverage herein above described. The Board shall notify the Owners of any material adverse changes in the Association's insurance coverage.

11.3 **Copies of Policies.** Copies of all insurance policies (or certificates thereof showing the premiums thereon have been paid) shall be retained by the Association and shall be available for inspection by Owners at any reasonable time.

11.4 **Individual Owner's Property Insurance.** Each Owner shall purchase and at all times maintain a policy of personal liability and property insurance insuring the Owner's Lot, Residence, any Improvements to the Owner's Lot, and personal property.

11.5 **Trustee.** All insurance proceeds may, in the discretion of the Board of Directors, be paid to a trustee to be held and expended for the benefit of the Owners, Mortgagees and others, as their respective interests shall appear.

11.6 **Adjustment of Losses.** The Board is appointed attorney-in-fact by each Owner to negotiate and agree on the value and extent of any loss under any policy carried pursuant to this Article. The Board is granted full right and authority to compromise and settle any claims or enforce any claim by legal action or otherwise and to execute releases in favor of any insured.



ARTICLE 12. DAMAGE OR DESTRUCTION; CONDEMNATION

12.1 Damage to or Destruction of Improvements to Association Property. In the event of damage to or destruction of any Improvement to the Common Elements or to any other real property owned by the Association, the Board of Directors shall, in its discretion and based upon considerations such as the existence of insurance proceeds from insurance coverage for such damage or destruction and the frequency of use of the Improvement, determine whether to repair or replace the damaged or destroyed Improvement. If any such damage or destruction was insured against and the insurance proceeds are insufficient to cover the costs of repair or replacement of the damaged or destroyed Improvement, and if the Board elects to repair or replace the Improvement, the Association may levy a Special Assessment against the Members as provided in this Declaration to cover the additional cost of the repair or replacement not covered by the insurance proceeds. If the Board elects not to repair or replace the Improvement, the applicable insurance proceeds shall be used in the manner consistent with the purposes of the Association and as determined by the Board.

12.2 Damage to or Destruction of Improvements to Lots. In the event of damage to or destruction of the Improvements on any Lot, the Owner of such Lot shall (i) completely repair or rebuild the Improvements to the same state as they existed prior to such damage or destruction or in any other manner approved by the Architectural Control Committee in accordance with Article 8, or (ii) completely remove all remaining portions of such damaged or destroyed Improvements. Such repair, rebuilding, or removal shall be commenced within a reasonable time, which shall in no event exceed one (1) year after the occurrence of the damage or destruction and shall be completed within one (1) year after the date of commencement unless a longer period is agreed to in writing by the Board.

12.3 Condemnation of Common Elements. If at any time all or any portion of any Common Elements, or any interest therein, shall be taken for any public or quasi-public use, under any statute, by right of eminent domain, or by private purchase in lieu of eminent domain, the entire compensation or award in condemnation, shall be paid to the Association and shall be used in the manner determined by the Board, provided that such use shall not be inconsistent with the purposes of the Association. The Association shall represent the interests of all Owners in any proceedings relating to such condemnation.

12.4 Condemnation of Lots. If an entire Residence or Lot, or so much thereof as to render the remainder unfit for use as a residence, is condemned or taken for a public or quasi-public use, pursuant to any statute, by right of eminent domain, or by private purchase in lieu of eminent domain, the Owner's membership in the Association shall terminate as of the last day of the month in which the condemner obtains the right to possession, or upon Owner's vacating the premises, whichever occurs last. If only a portion of such Residence or Lot is taken and the remainder is fit for use as a Residence,



the Owner shall continue to be a Member of the Association and the allocated interests of the affected Lot shall be reduced in proportion to the reduction in the size of that Lot, or on any other basis specified in this Declaration. In any condemnation action involving an Owner's Residence or Lot, the Association shall have the right to seek compensation for any damages incurred by the Association.

ARTICLE 13. PROTECTION OF LENDERS

13.1 Assessment Lien Subordinated. No amendment of this Declaration shall affect any of the rights of the holder of any Mortgage which is made in good faith and for value, if such Mortgage is recorded and notice of the delivery and recording thereof is given to the Association prior to the recording of such amendment.

13.2 Default by Owner; Mortgagee's Right to Vote. In the event of a default by any Owner under a Mortgage encumbering such Owner's Lot, the Mortgagee under such Mortgage shall, upon: (i) giving written notice to the defaulting Owner; (ii) recording a Notice of Default; and (iii) delivering a copy of such recorded Notice of Default to the Association, have the right to exercise the vote of the Owner at any regular or special meeting of the Association held only during such period as such default continues.

13.3 Breach; Obligation after Foreclosure. No breach of any provision of this Declaration by Declarant, the Association or any Owner shall impair or invalidate the lien of any recorded Mortgage made in good faith and for value and encumbering any Lot. The Declarant, the Association or their successor and assigns shall be obligated to abide by all of the covenants, conditions, restrictions, limitations, reservations, grants of easements, rights, rights-of-way, liens, charges and equitable servitudes provided for in this Declaration as it may be amended from time to time with respect to any person who acquires title to or any beneficial interest in any Lot through foreclosure, trustee's sale or otherwise.

13.4 Right to Examine Books and Records of the Association. All Owners, Mortgagees, insurers and guarantors of any Mortgages on any Lot shall have the right, upon written request to the Association, to:

- (a) Examine current copies of the Governing Documents and the Association's books, records, budgets, reserve studies and financial statements, during normal business hours;
- (b) Require the Association to provide an audited statement for the preceding fiscal year: (i) at no expense to the requesting entity when the Properties consist of fifty (50) or more Lots; and (ii) at the requesting entity's expense when the Properties development consists of fewer than fifty (50) Lots and no audited statement is available; and
- (c) Receive a written notice of all meetings of the Association and designate a representative to attend all such meetings.



0656738

Page: 58 Of 68

BK- 1005
PG- 724
10/03/2005

BK- 0106
PG- 1941
01/09/2006

0665170 Page: 59 Of 71

13.5 Declaration to Conform With Mortgagee Requirements. It is the intent of this article that this Declaration, the Articles of Incorporation, the Bylaws and the development in general, shall now and in the future meet all requirements of any institutional Mortgagee intending to secure its Mortgage by a Lot or necessary to purchase, guarantee, insure or subsidize any Mortgage of a Lot by the Federal Home Loan Mortgage Corporation, the Federal National Mortgage Association or the Veterans' Administration.

ARTICLE 14. ANNEXATIONS AND SUPPLEMENTAL DECLARATIONS

14.1 Declarant Annexations. Declarant shall have the right to annex all or any portions of any subsequent Phase property, if any shall exist to the Development so as to be subject to this Declaration and so that membership in the Association shall be appurtenant to ownership of Lots within the annexed Phase.

14.2 Association Annexations. In addition to annexations effected by the Declarant, annexations of other real property may be made by the Association with the approval by vote or written consent of Members entitled to exercise not less than two-thirds of the Voting Power of the Membership of the Association. Upon obtaining the requisite approval of the Members pursuant to this section, the owner of the property being annexed shall Record a Declaration of Annexation and, if appropriate, a Supplemental Declaration, as more particularly described below.

14.3 Declarations of Annexation. A Declaration of Annexation shall be recorded covering the applicable portion of the subsequent Phase property or other real property being annexed. The Declaration of Annexation shall identify the Lots and Common Elements, if any, within the annexed property, and may include a Supplemental Declaration which adds or modifies restrictions and rights with respect to the annexed property.

14.4 Assessments in Annexed Phase. Declarant shall pay to the Association, concurrently with the closing of the escrow for the first sale of a Lot in an annexed Phase, appropriate amounts for reserves for replacement or deferred maintenance of Common Elements and Improvements in the annexed Phase.

14.5 Supplemental Declarations. Declarant and the Association shall have the right to Record a Supplemental Declaration against future Phases of the Property. The Supplemental Declaration may include restrictions which are different from the restrictions contained in this Declaration. A Supplemental Declaration may not alter the general common plan or scheme created by this Declaration, revise any restriction imposed by a governmental entity as a condition of Subdivision Map approval (without the consent of that entity) or revoke, modify or add to the covenants, conditions and restrictions imposed by this Declaration with respect to portions of the Properties initially subject to this Declaration or Properties annexed prior the annexed Phase.



ARTICLE 15. DECLARANT'S DEVELOPMENT RIGHTS

15.1 Declarant's Right to Develop the Properties. The Association and Owners shall not do anything to interfere with the right of Declarant to subdivide, sell, or rent any portion of the Properties, or the right of Declarant to complete excavation, grading, construction of Improvements or other development activities to and on any portion of Development or to alter the foregoing and its construction plans and designs, or to construct such additional Improvements as Declarant deems advisable in the course of development of the Properties so long as any Lot or any portion of the Development is owned by Declarant. Such right shall include, but shall not be limited to, all grading work as may be approved by the County or other agency having jurisdiction, and erecting, constructing and maintaining on or within the Properties such structures, signs and displays as may be reasonably necessary for the conduct of its business of completing the work and disposing of the same by sale, lease or otherwise. Each Owner, by accepting a deed to a Lot, hereby acknowledges that any construction or installation by Declarant may impair the view of such Owner, and hereby consents to such impairment.

15.2 Use of Common Elements by Declarant. Declarant may enter upon the Common Elements, for the benefit of Declarant or for the benefit of portions of the Development whether or not then annexed, or any combination of them, to complete the development, improvement and sale of Lots and the construction of any landscaping or other Improvement to be installed on the Common Elements. Declarant shall also have the right of nonexclusive use of the Common Elements and the Common Facilities, without charge, for sales, display, access, ingress, egress, exhibition and occasional special events for promotional purposes, which right Declarant hereby reserves; provided, however, that such use rights shall terminate on the date on which Declarant no longer owns any Lots within the Properties and Declarant's unilateral right to annex portions of the Development has expired. Such use shall not unreasonably interfere with the rights of enjoyment of the other Owners as provided herein and all direct costs and expenses associated with Declarant sales and promotional activities (including, without limitation, any costs or expenses required to clean or repair any portion of the Common Elements that are damaged or cluttered in connection with such activities) shall be borne solely by the Declarant and any other sponsor of the activity or event. The rights reserved to the Declarant by this section shall extend to any employee, sales agents, prospective purchasers, customers and/or representatives of the Declarant.

15.3 Amendment of Development Plans. Declarant may amend its plans for the Development, combine or split Lots and apply for changes in any development agreements, changes in zoning, use and use permits, for any property within the Development. Declarant reserves the right to add or withdraw, annex or de-annex, redesign and change plans, real estate, Lots, Common Elements and Improvements in accordance with this Declaration and applicable Nevada laws and regulations

15.4 Independent Architectural Review. For so long as the Declarant has the right to appoint any members of the ACC, the Declarant shall have the right to initiate



action to correct or prevent any activity, condition or Improvement that is not in substantial compliance with approved plans and specifications to the same extent as the Association if: (i) the ACC has issued a Notice of Noncompliance; and (ii) the Association, after having a reasonable opportunity to do so, does not initiate enforcement action.

15.5 Termination of Declarant's Rights. If the Declarant conveys all of its rights, title and interest in the Development to any person or entity and the acquiring person or entity is designated as a successor Declarant as to all the property conveyed, then Declarant shall be relieved of the performance of any further duty or obligation hereunder, and successor Declarant shall be obligated to perform all such duties and obligations of Declarant. This section shall not terminate any responsibility of the Declarant for acts or omissions occurring prior to the conveyance to such person or entity. However, Declarant may to enter into a contract or agreement dealing with such acts or omissions.

15.6 No Amendment or Repeal. So long as Declarant owns any Lots within the Development, the provisions of this article may not be amended or repealed without the consent of Declarant.

ARTICLE 16. AMENDMENTS

16.1 Amendment before First Close of Escrow. Before the close of escrow for the first sale of a Lot within the Properties to a purchaser other than Declarant, this Declaration and any amendments to it may be amended in any respect or revoked by the execution by Declarant and any Mortgagee of record by an instrument amending or revoking the Declaration. The amending or revoking instrument shall make appropriate reference to this Declaration and its amendments and shall be recorded.

16.2 Amendment after First Close of Escrow. After the close of escrow for the first sale of a Lot within the Properties to a purchaser other than Declarant, this Declaration may be amended or revoked in any respect, subject to Section 15.6, upon compliance with the following provisions:

(a) **Member Approval Requirements.** Any amendment shall be approved by the vote or assent by written ballot of the holders of not less than fifty-one percent (51%) of the Total Voting Power of the Members. Notwithstanding the foregoing, the percentage of the voting power necessary to amend a specific clause or provision of this Declaration shall not be less than the percentage of affirmative votes prescribed for action to be taken under that clause.

(b) **Declarant Approvals.** Article 15 may only be amended with the prior written consent of the Declarant for so long as the Declarant owns a Lot within the Development.



(c) Right of Amendment of Requested by Governmental Mortgage Agency or Federally Chartered Lending Institutions. Anything in this article to the contrary notwithstanding, Declarant reserves the right to amend all or any part of this Declaration to such an extent and with such language as may be requested by Governmental Mortgage Agencies which require such an amendment as a condition precedent to such agency's approval of this Declaration, or by any federally chartered lending institution as a condition precedent to lending funds upon the security of any Lot(s) or Parcel(s) or any portions thereof. Any such amendment shall be effectuated by the recordation, by Declarant, of a Certificate of Amendment duly signed by or on behalf of the authorized agents, or authorized officers of Declarant, as applicable, with their signatures acknowledged, specifying the Governmental Mortgage Agency, or the federally chartered lending institution requesting the amendment and setting forth the amendatory language requested by such agency or institution. Recordation of such a Certificate shall be deemed conclusive proof of the agency's or institution's request for such an amendment, and such Certificate, when recorded, shall be binding upon all of Lots and Common Elements comprising the development and all persons having any interest therein.

16.3 Restatements. This section describes the methods for restating the Declaration after an amendment.

(a) General. The Board has the right, by resolution without the necessity of consent by the Owners, to restate this Declaration when it has been properly amended pursuant to its requirements for amendment. Such restatement shall be effective upon execution of the restatement by any two (2) officers of the Association and its Recordation. Upon Recordation of the restatement, the restatement shall supersede the prior declaration and its amendments in their entirety, without, however, affecting the priority of the Declaration in the chain of title to all properties that are subject to the Declaration as established by the Declaration initial date of Recordation.

(b) Form of Restatement. The restatement shall restate the entire text of the original document, with these exceptions: (i) changes incorporating all amendments approved by the Owners; (ii) changes made to rearrange or delete the text for consistency with the approved amendments; (iii) changes made to delete material no longer legally effective or legally required, such as the provisions described in Article 15; (iv) the addition of a statement that the Board has authorized the restatement pursuant to this section; (v) changes made to delete any provision declared illegal by constitutional or statutory enactment, by regulation, or by controlling judicial opinion; and (vi) changes needed to distinguish the restatement from the original document, such as title, section, or subsection numbering changes.

16.4 Effective Date of Amendment. The amendment will be effective upon the Recording of a Certificate of Amendment, duly executed and certified by the president and secretary of the Association setting forth in full the amendment so approved and that



the approval requirements of subsections (a) and (b) of Article 16.3 have been duly met. If the consent or approval of any governmental authority, Mortgagee, or other entity is required under this Declaration to amend or revoke any provision of this Declaration, no such amendment or revocation shall become effective unless such consent or approval is obtained.

16.5 Amendments by Board. The Board of Directors may, without the approval of the Members, amend any part of this Declaration to the limited extent necessary to comply with the lending requirements of any federally chartered lending institution, as well as any amendments made solely to comply with a change in applicable federal, state or local legislation. Each Owner shall be deemed to appoint the Association as his or her attorney-in-fact to act with respect to any amendments which is solely for the purpose of complying with such lending requirements.

16.6 Reliance on Amendment. Any amendments made in accordance with the terms of this Declaration shall be presumed valid by anyone relying on them in good faith.

ARTICLE 17. GENERAL PROVISIONS

17.1 Headings. The headings used in this Declaration are for convenience only and are not to be used in interpreting the meaning of any of the provisions of this Declaration, or otherwise.

17.2 Severability. The provisions of this Declaration shall be deemed independent and severable, and the invalidity or partial invalidity or unenforceability of any provision hereof shall not invalidate any other provisions hereof.

17.3 Liberal Construction. The provisions of this Declaration shall be liberally construed to effectuate its purpose of fostering a plan of community ownership and occupancy and of management of the Development for the benefit of the community.

17.4 Number; Gender; Shall/May. The singular shall include the plural and the plural the singular unless the context requires the contrary, and the masculine, feminine, and neuter shall each include the masculine, feminine, or neuter, as the context requires. The use of the term "may" in this Declaration indicates discretion or choice, and the use of the term "shall" in this Declaration means imperative, mandatory or imposing an absolute duty.

17.5 Easements Reserved and Granted. Any and all easements referred to herein shall be deemed reserved or granted, or both reserved and granted, as appropriate, by reference to this Declaration in a deed to any Lot.

17.6 Power of Attorney. To the extent necessary to carry out and enforce the provisions of this Declaration, an irrevocable power of attorney coupled with an interest is granted to the Association by the Owners and each of them.

17.7 Term. The covenants, conditions, restrictions, limitations, reservations, grants of easement, rights, rights-of-way, liens, charges, and equitable servitudes contained in this Declaration shall run with and shall benefit and burden all of the real property subject to this Declaration, including without limitation the Lots and the Common Elements, and shall inure to the benefit of and be binding upon the Owners, the Association, its Board of Directors and officers, and their respective agents and successors in interest, for a term of fifty (50) years from the date of Recordation of this Declaration. Thereafter the term shall be automatically extended for successive periods of ten (10) years each, unless within the six (6) months prior to the expiration of the initial fifty (50) year term or any ten (10) year extension period a written instrument, approved by at least an Absolute Majority, terminating the effectiveness of this Declaration is Recorded.

DATED: December 20th, 2005

By Declarant:

Rocky Terrace Estates, LLC

By: *Lawrence R. Walsh*
LAWRENCE R. WALSH, Manager

By: *Jeffrey P. Pisciotta*
JEFFREY P. PISCIOTTA, Manager

STATE OF NEVADA)
 :SS.
County of Douglas)

On this 20th day of December, 2005 before me, the undersigned, a notary public, personally appeared LAWRENCE R. WALSH, and who acknowledged to me that he executed the foregoing instrument, freely and voluntarily, and for the uses and purposes therein mentioned.

IN WITNESS WHEREOF, I hereunto set my hand and affixed my official seal the day and year herein written.

 CHARLENE L. HANOVER
NOTARY PUBLIC
STATE OF NEVADA
Appt. Recorded in Douglas County
My Appt. Expires February 3, 2007
No: 98-2565-5

Charlene L. Hanover
NOTARY PUBLIC

BK- 0106
PG- 1947
01/09/2006
0665170 Page: 65 Of 71

STATE OF NEVADA)
 :SS.
County of Douglas)

On this 20th day of December, 2005 before me, the undersigned, a notary public, personally appeared JEFFREY P. PISCIOTTA, and who acknowledged to me that he executed the foregoing instrument, freely and voluntarily, and for the uses and purposes therein mentioned.

IN WITNESS WHEREOF, I hereunto set my hand and affixed my official seal the day and year herein written.

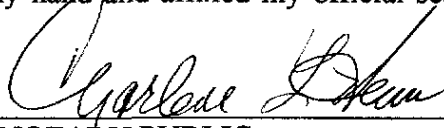

NOTARY PUBLIC

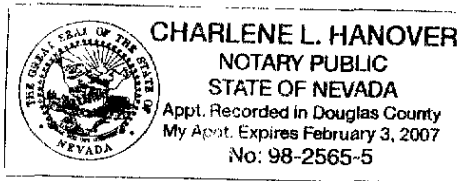

17.7 Term. The covenants, conditions, restrictions, limitations, reservations, grants of easement, rights, rights-of-way, liens, charges, and equitable servitudes contained in this Declaration shall run with and shall benefit and burden all of the real property subject to this Declaration, including without limitation the Lots and the Common Elements, and shall inure to the benefit of and be binding upon the Owners, the Association, its Board of Directors and officers, and their respective agents and successors in interest, for a term of fifty (50) years from the date of Recordation of this Declaration. Thereafter the term shall be automatically extended for successive periods of ten (10) years each, unless within the six (6) months prior to the expiration of the initial fifty (50) year term or any ten (10) year extension period a written instrument, approved by at least an Absolute Majority, terminating the effectiveness of this Declaration is Recorded.

DATED: SEPTEMBER 30, 2005

By Declarant:

J & L Ventures, LLC,
a Nevada limited liability company

By: Lawrence R. Walsh
LAWRENCE R. WALSH, Manager

By: Jeffrey P. Pisciotto
JEFFREY P. PISCIOTTA, Manager

STATE OF NEVADA)
 :ss.
County of Douglas)

On this 30th day of September, 2005 before me, the undersigned, a notary public, personally appeared LAWRENCE R. WALSH, and who acknowledged to me that he executed the foregoing instrument, freely and voluntarily, and for the uses and purposes therein mentioned.

IN WITNESS WHEREOF, I hereunto set my hand and affixed my official seal the day and year herein written.



0656738 Page: 64 Of 68 BK- 1005
PG- 730
10/03/2005

BK- 0106
PG- 1949
0665170 Page: 67 Of 71 01/09/2006

Charlene L. Hanover
NOTARY PUBLIC

STATE OF NEVADA)
 :SS.
County of Douglas)

On this 30th day of September, 2005 before me, the undersigned, a notary public, personally appeared **JEFFREY P. PISCIOTTA**, and who acknowledged to me that he executed the foregoing instrument, freely and voluntarily, and for the uses and purposes therein mentioned.

IN WITNESS WHEREOF, I hereunto set my hand and affixed my official seal the day and year herein written.

Charlene L. Hanover
NOTARY PUBLIC

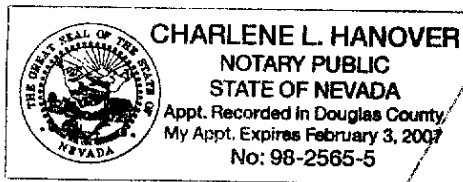

BK- 0106
PG- 1950
0665170 Page: 68 Of 71 01/09/2006



BK- 1005
PG- 731
0656738 Page: 65 Of 68 10/03/2005

Exhibit "A" The Development

All of that certain real property located in Douglas County, Nevada, more particularly described as follows:

Legal Description: The land referred to herein is situated in the State of Nevada, County of Douglas, described as follows:

A parcel of land located within a portion of the Southeast one-quarter (SE ¼) and Southwest one-quarter (SW ¼) of Section 8, Township 12 North, Range 20 East, Mount Diablo Meridian, more particularly described as follows:

Commencing at the corner common to Sections 7, 8, 17 and 18, Township 12 North, Range 20 East, M.D.M., a found ½" iron pipe, no tag, as shown on the Record of Survey to Support a Boundary Line Adjustment for Chris and Valree Hellwinkel recorded June 26, 2003 in the office of Recorder, Douglas County, Nevada as Document No. 581510;

thence along the south line of the Southwest one-quarter of said Section 8, North 89° 34' 00" East, 2190.55 feet to the POINT OF BEGINNING;

thence North 00° 22' 36" West, 253.92 Feet;

thence North 04° 12' 53" East, 175.54 Feet;

thence North 26° 40' 16" East, 153.70 Feet;

thence North 42° 53' 29" East, 263.70 Feet;

thence North 53° 00' 38" East, 112.05 Feet;

thence North 58° 20' 02" East, 158.36 Feet;

thence North 57° 00' 53" East, 173.82 Feet;

thence North 72° 05' 47" East, 155.22 Feet;

thence North 59° 49' 18" East, 126.97 Feet;

thence North 73° 32' 54" East, 132.46 Feet;

thence North 44° 16' 51" East, 220.78 Feet to a point on the south line of Adjusted A.P.N., 1120-08-000-020 as shown on said Record of Survey;

thence along said south line the following courses:

Along an existing fence, North 89° 15' 04" East, 227.54 Feet to an angle point in an existing fence line;

South 69° 26' 09" East, 115.24 feet to an angle point in said existing fence line;

South 85° 06' 08" East, 83.61 feet to an angle point in said existing fence line;

South 55° 10' 45" East, 26.82 feet to an angle point in said existing fence line;

South 40° 14' 29" East, 53.69 feet to an angle point in said existing fence line

Along an existing fence line, South 24° 05' 33" East, 30.26 feet to an angle point in an existing fence line;



0656738

Page: 66 Of 68

BK- 1005
PG- 732
10/03/2005

BK- 0106
PG- 1951
01/09/2006
0665170 Page: 69 Of 71

**Exhibit "A" (Continued)
The Development**

Legal description – continued

South 00° 20' 09" West, 184.08 feet;

North 89° 06' 08" East, 76.26 feet to a point on the east line of the Southwest one-quarter of the South east one-quarter of said Section 8,

thence along said ease line, South 00° 12' 27" East 987.48 feet to the southeast corner of said Southwest one-quarter of the Southeast one-quarter of Section 8;

thence along the south line of the Southeast one-quarter of Section 8 , South 89° 38' 02" West, 1318.48 feet to the south one-quarter corner of said Section 8, a found ½" iron pipe, no tag;

thence along said south line of the Southwest one-quarter of said Section 8, South 89° 34' 00" West, 416.19 feet to the POINT OF BEGINNING.

Reference is made Record of Survey recorded May 3, 2004 in Book 0504, at page 104, as Document No. 612056.

ASSESSOR'S PARCEL NO. 1220-08-002-021

"IN COMPLIANCE WITH NEVADA REVISED STATUTE 111.312, THE HEREIN ABOVE LEGAL DESCRIPTION WAS TAKEN FROM INSTRUMENT RECORDED NOVEMBER 8, 2004, BOOK 1104, PAGE 3769, AS FILE NO. 628749, RECORDED IN THE OFFICIAL RECORDS OF DOUGLAS COUNTY, STATE OF NEVADA."

0656738 Page: 67 Of 68 BK- 1005
PG- 733
10/03/2005



0665170 Page: 70 Of 71 BK- 0106
PG- 1952
01/09/2006

Exhibit "B"

Fence Design Specifications

1. 4X6 POST AT 8' O.C. TYPICAL
2. 2X6 TOP BOARD (CAP)
3. 2X6 STRINGER (BOTH SIDES)
4. 1X6 VERTICAL FENCE BOARDS
5. 2X6 BOTTOM BOARD
6. FINISH GRADE
7. CONCRETE FOOTING
8. COMPACTED SUBGRADE

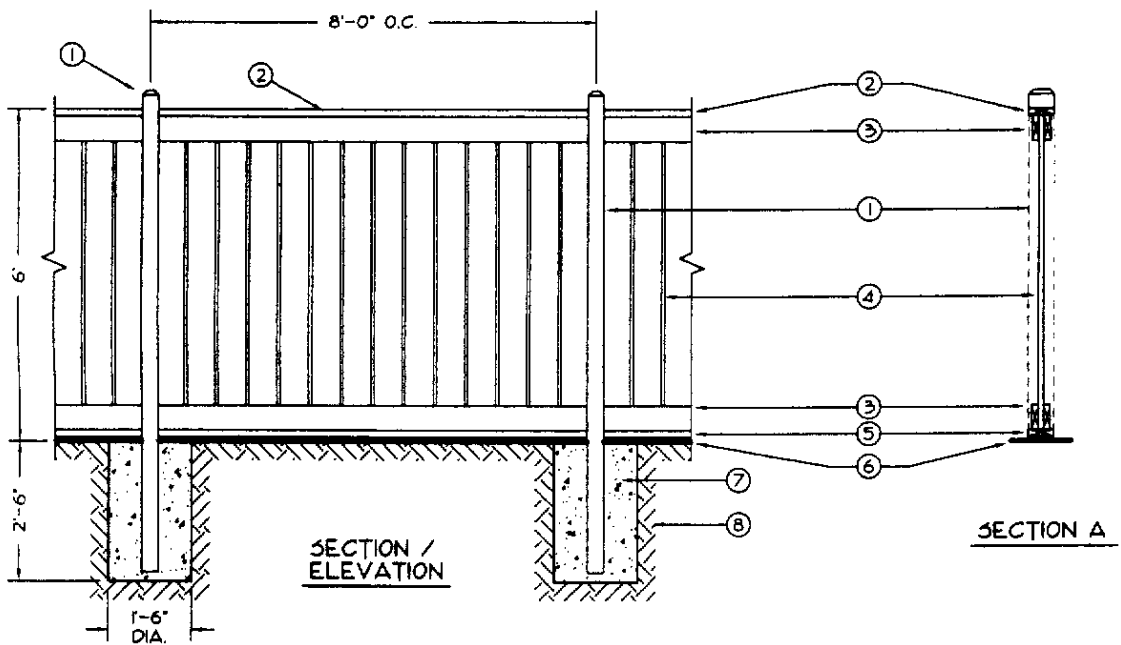
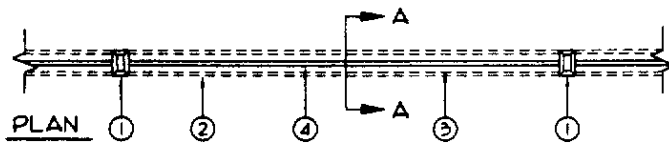
- A ALL WOOD MEMBERS OF WOOD FENCE, INCLUDING VERTICAL SLATS & POSTS SHALL BE REDWOOD-CONSTRUCTION GRADE
- B ALL WOOD MEMBERS TO BE FASTENED WITH GALVANIZED SCREWS. NO NAILS OR STAPLES ALLOWED



WOOD FENCE DETAIL

N.T.S.



BK- 0106
PG- 1953
0665170 Page: 71 Of 71 01/09/2006



BK- 1005
PG- 734
0656738 Page: 68 Of 68 10/03/2005